

EUCNC
6G Summit

Virtual Conference (Porto, Portugal)
8-11 June 2021



imec

**Instructions to Antennas:
6G on the back of an envelope (or napkin)**

Prof. Dr. Ir. Michael Peeters — VP R&D Connectivity — 20210519



Keynotes...

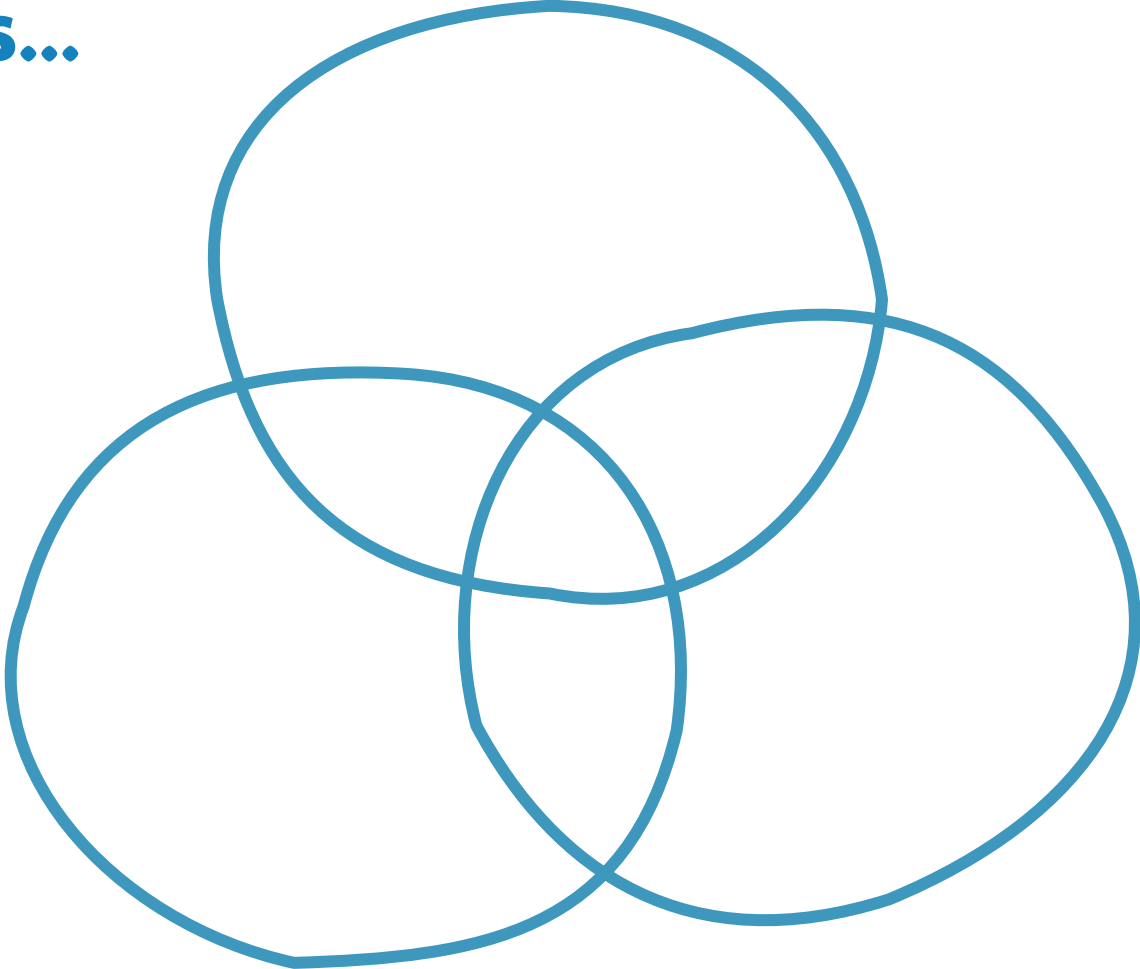

Keynotes...

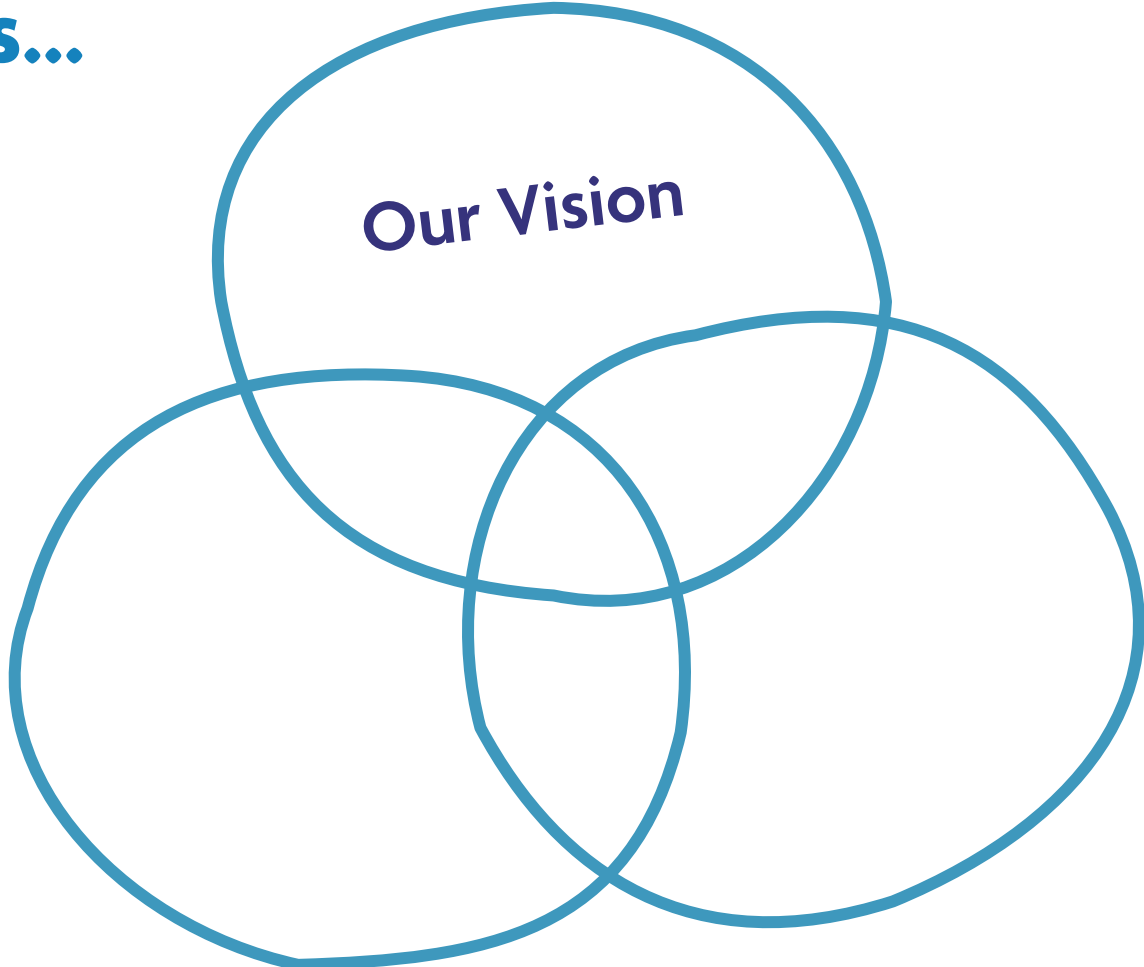

Keynotes...

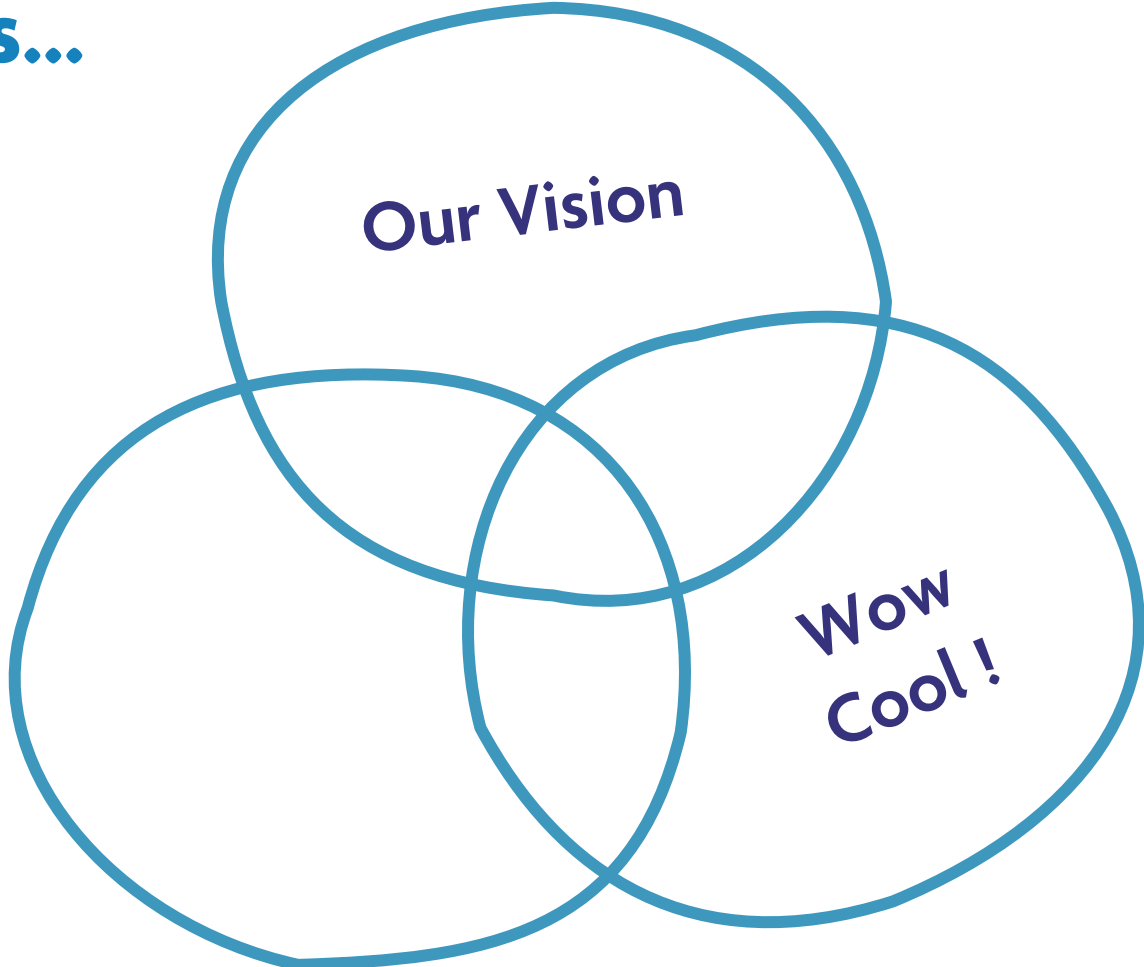

Keynotes...

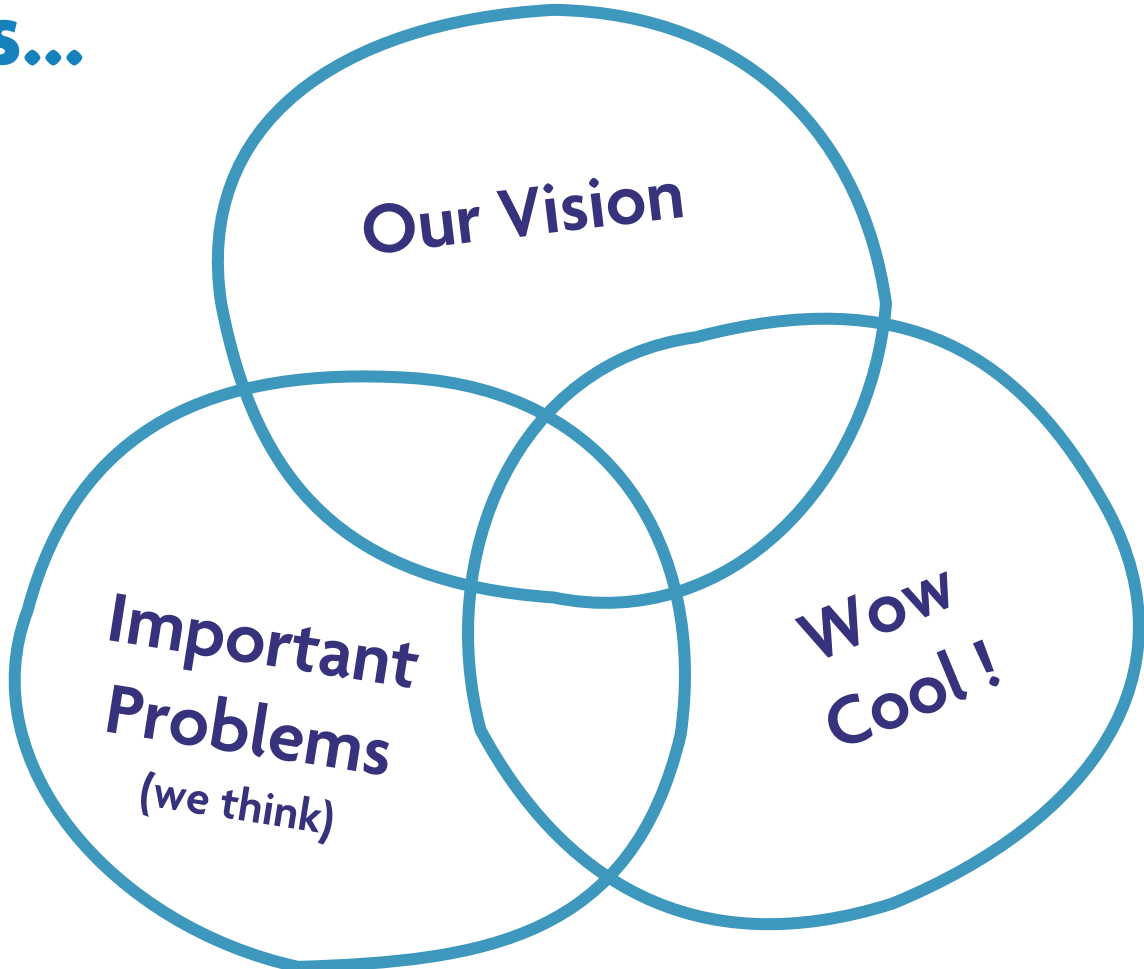

Keynotes...

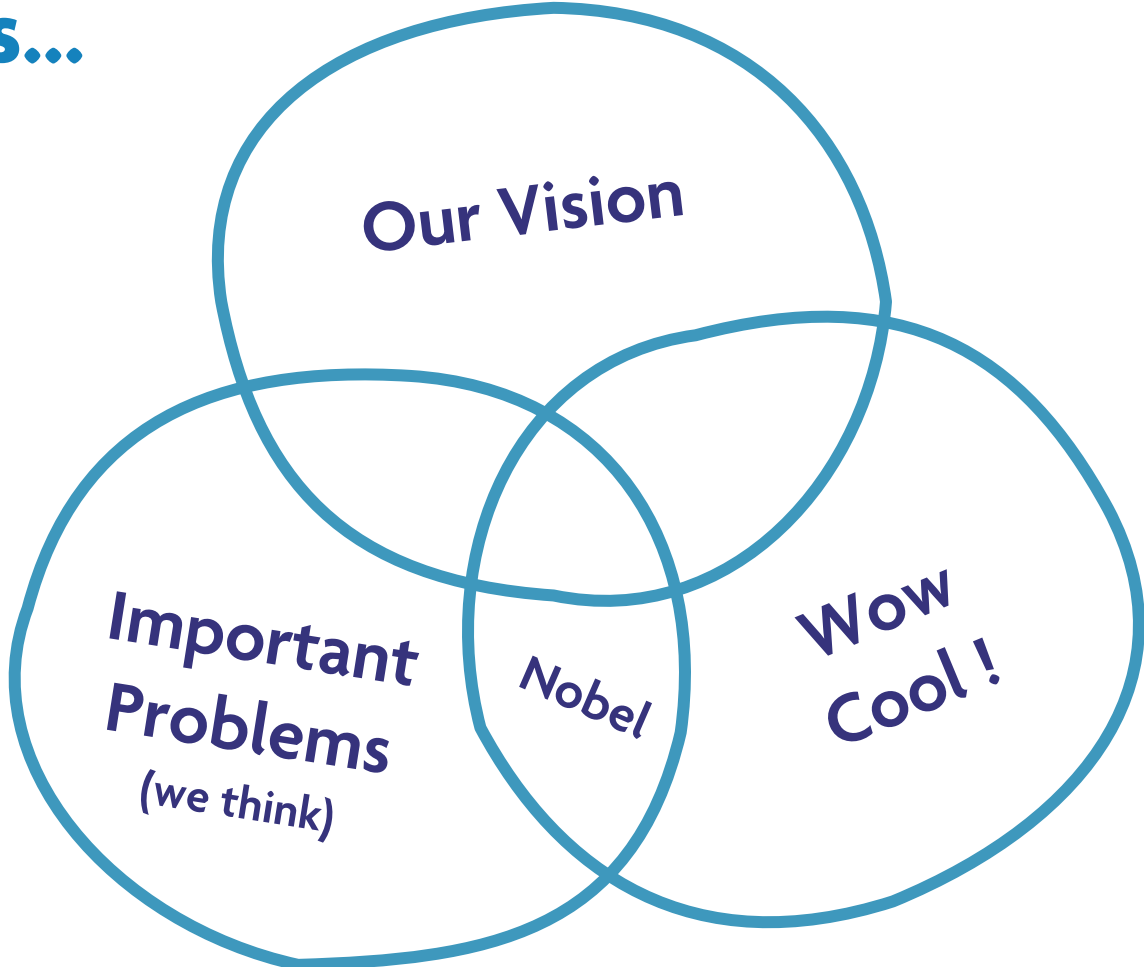

Keynotes...

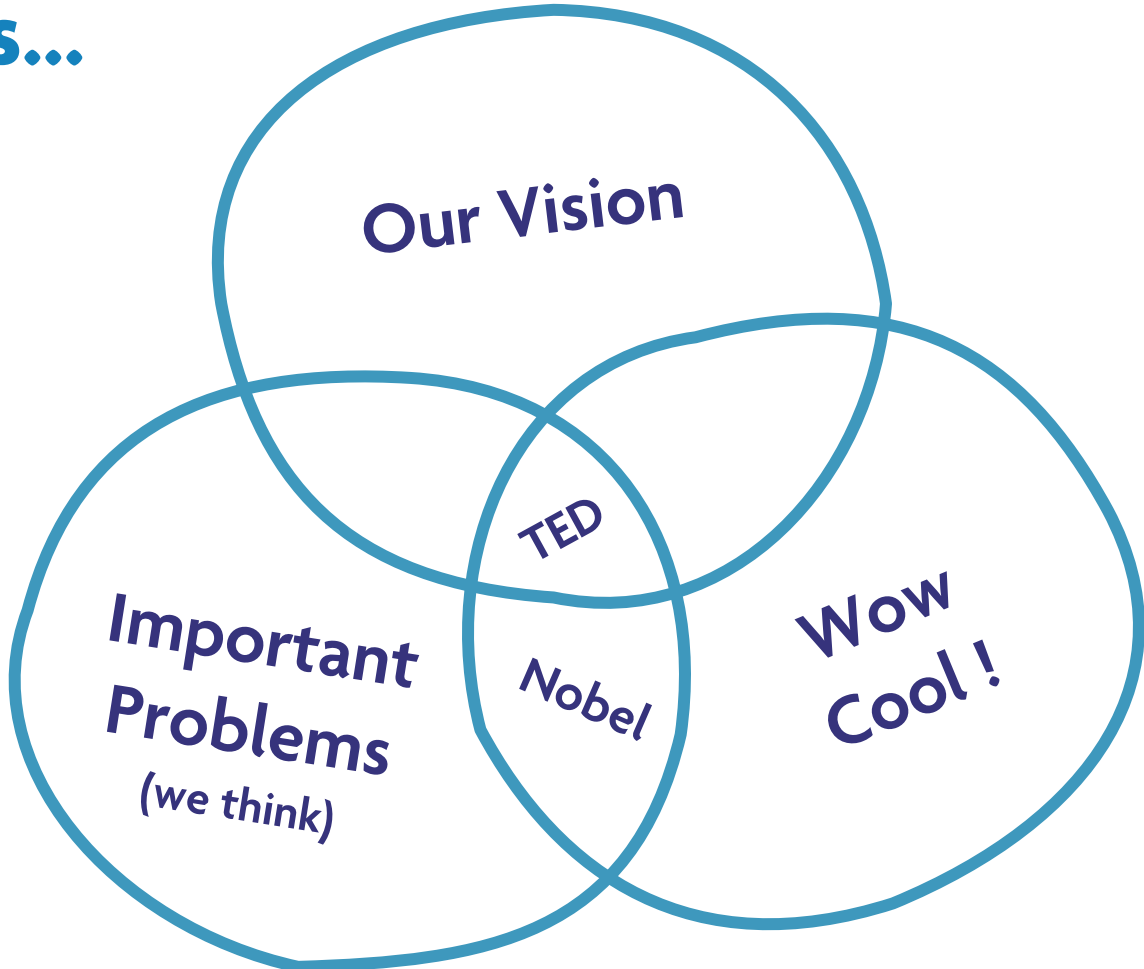

Keynotes...

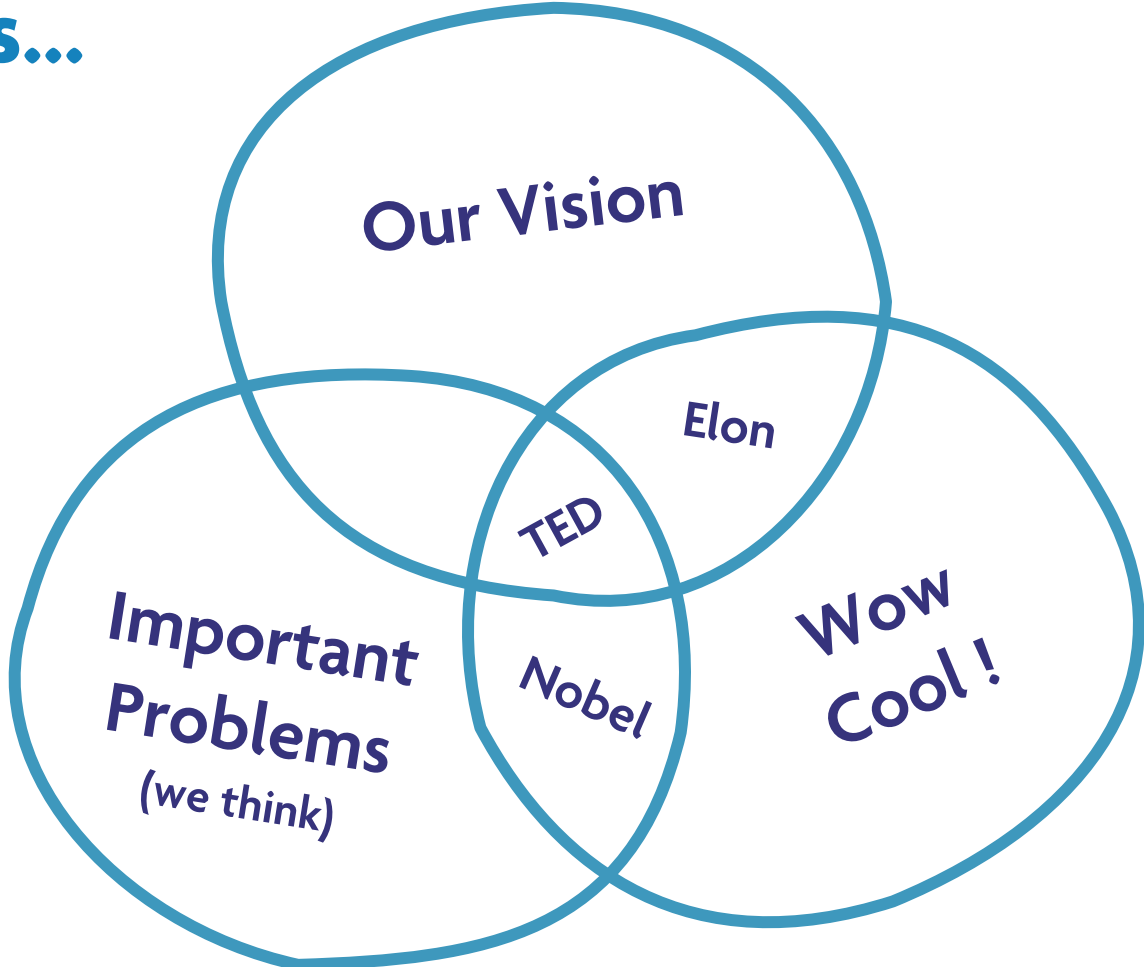

Keynotes...

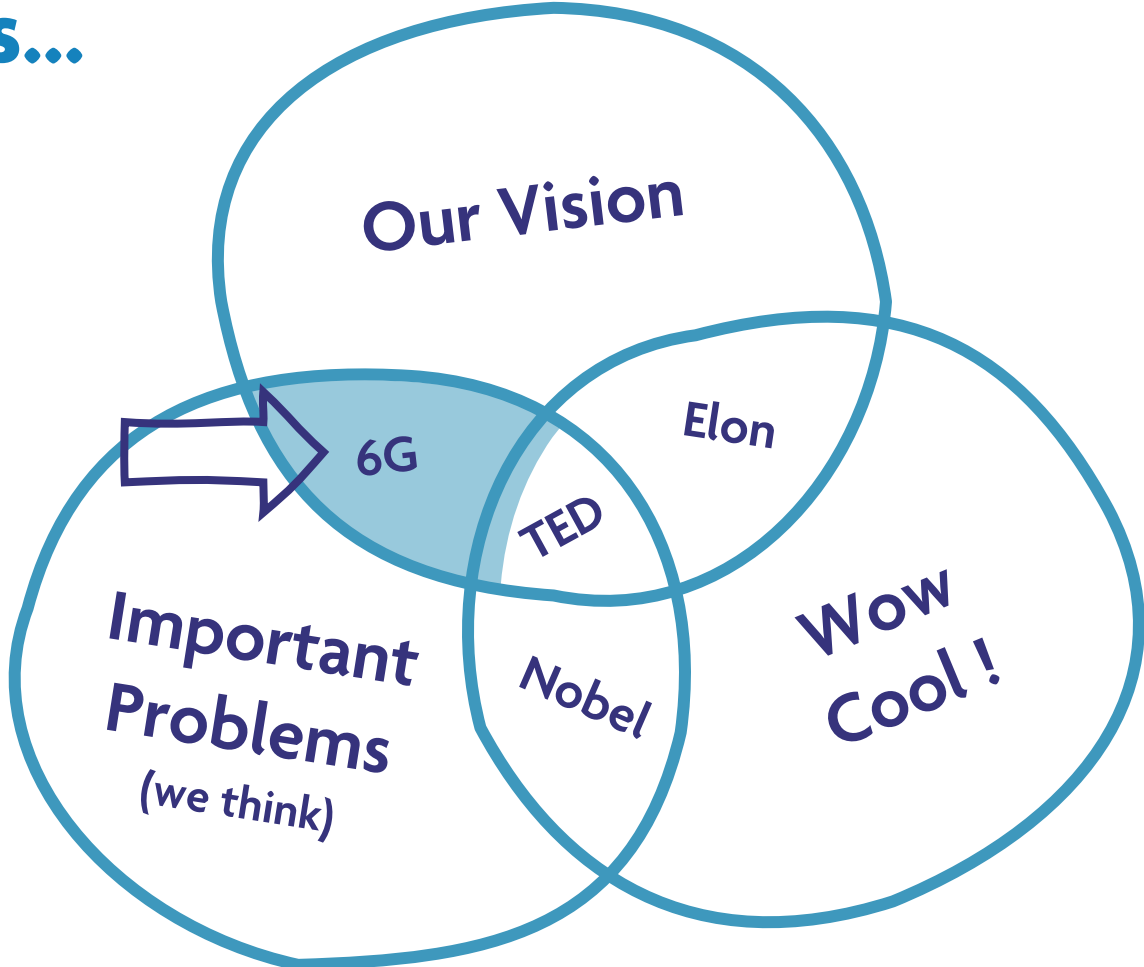

ORGANISMS COMMUNICATE TO IMPROVE THEIR CHANCES OF ACHIEVING THEIR GOALS



doi 10.1098/rspb.2000.1140

On the advantages of information sharing

Michael Lachmann^{1*}, Guy Sella^{1,2} and Eva Jablonka³

¹*Department of Biological Sciences, Stanford University, Stanford, CA 94305, USA*

²*School of Mathematics, Raymond and Beverly Sackler Faculty of Exact Sciences, Tel-Aviv University, Tel-Aviv 69978, Israel*

³*Cohn Institute for the History and Philosophy of Science and Ideas, Tel-Aviv University, Tel-Aviv 69978, Israel*

During the evolution of life, there have been several transitions in which individuals began to cooperate, forming higher levels of organization, and sometimes losing their independent reproductive identity. For example, multicellularity and insect societies evolved independently multiple times. Several factors that confer evolutionary advantages on higher levels of organization have been proposed. In this paper we highlight one additional factor: the sharing of information between individuals. Information sharing is not subject to the intrinsic conservation laws that characterize the sharing of physical resources. A simple model will illustrate how information sharing can result in aggregates in which the individuals both receive more information about their environment and pay less for it. This may have played a role in the evolution of higher levels of organization.

Keywords: information sharing; multicellularity; ensociality; public goods; evolution

sense centric



human centric



(10 Gbps retina) (30 Mbps cochl.)

10 Mbps

(10 kbps layer IV)



2 Mbps



100 kbps



100 kbps



135 Mbps

200 Mbps saturates a human being...

Fundamental trends

But be careful of aggregated numbers

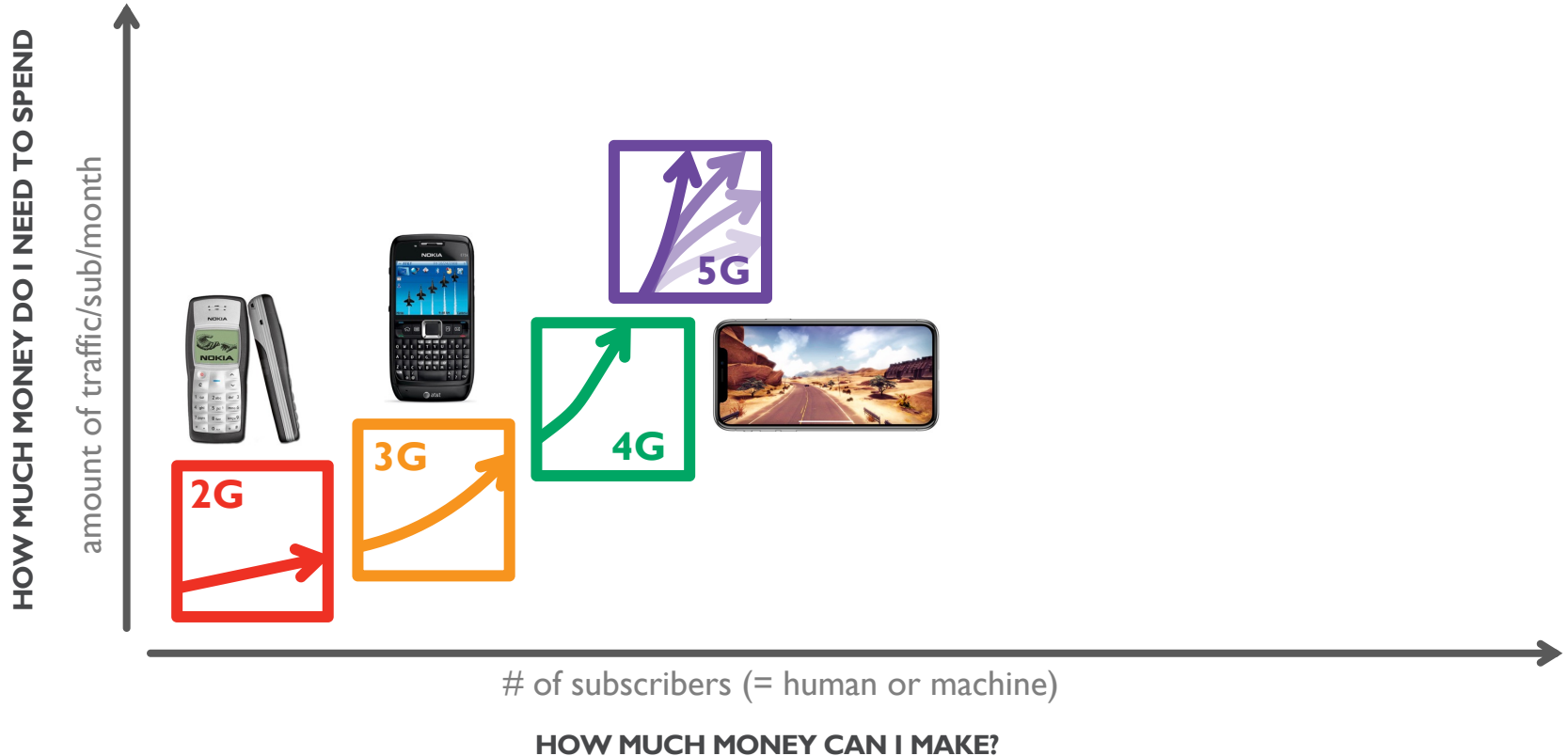

Fundamental trends

But be careful of aggregated numbers

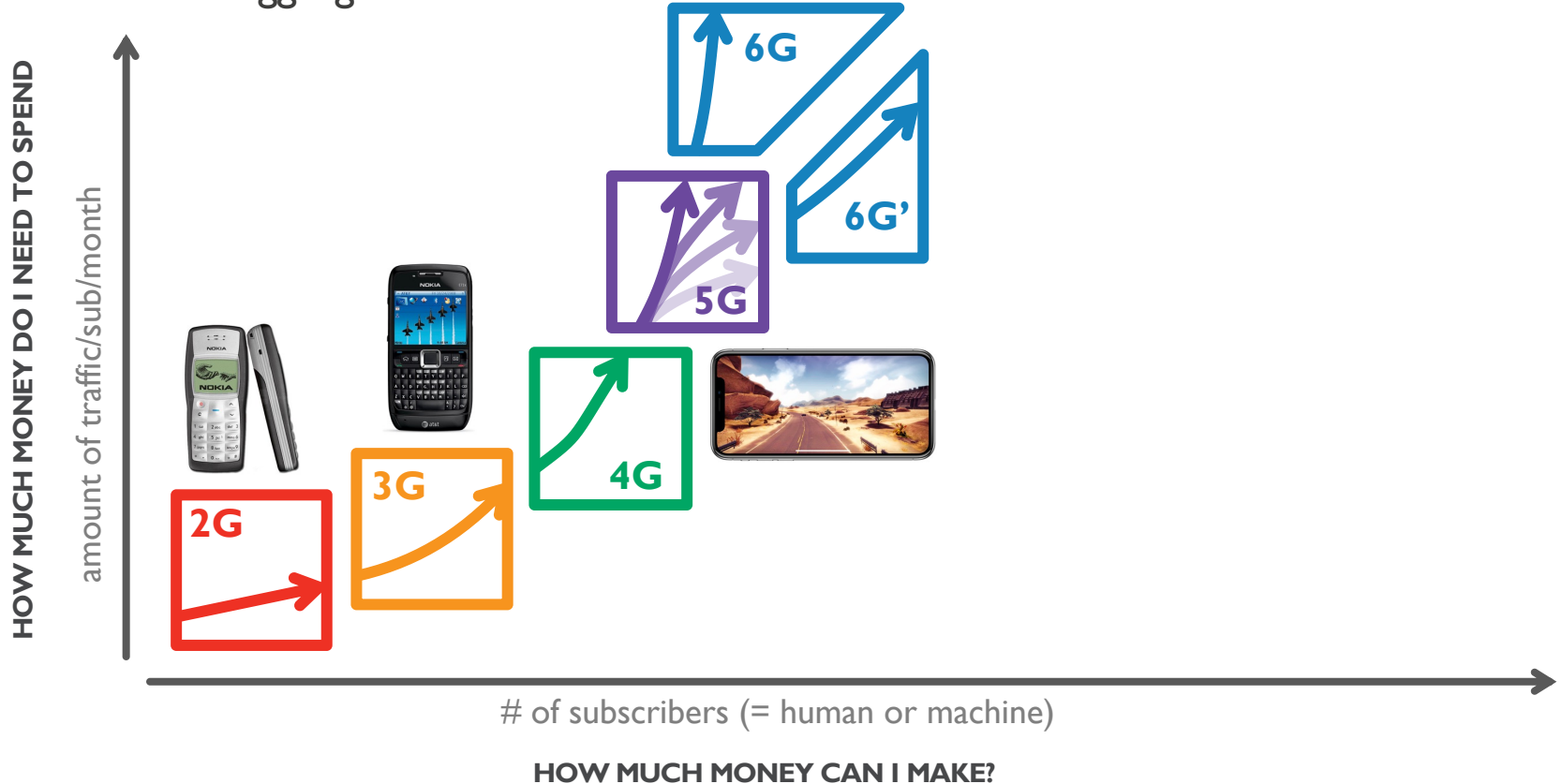

Fundamental trends

But be careful of aggregated numbers

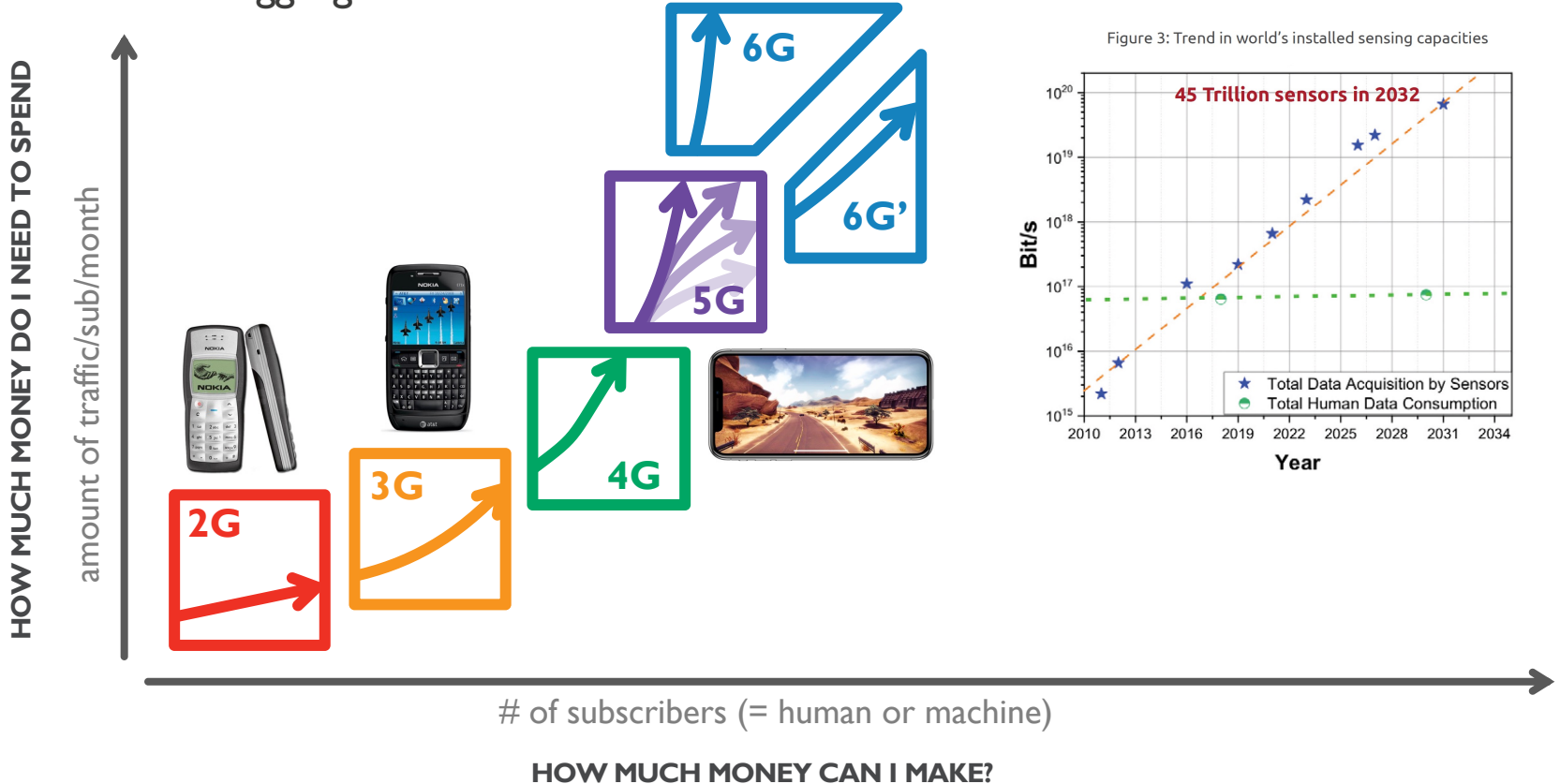
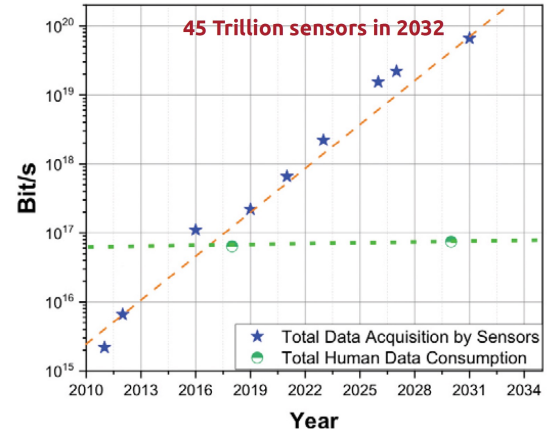

Figure 3: Trend in world's installed sensing capacities



Communication saturation

Usecases that will (always) drive the market



| communication at a distance | People | Pretend-People | Machines |
|-----------------------------|--------------------|------------------------------|-------------------------|
| People | voice, video calls | entertainment, gaming, Xbots | body-machine interfaces |
| | | XR | |
| Pretend-People | | conversation bots, training | neural network training |
| Machines | | | automation |
| | | | agent-2-agent |

5G

6G

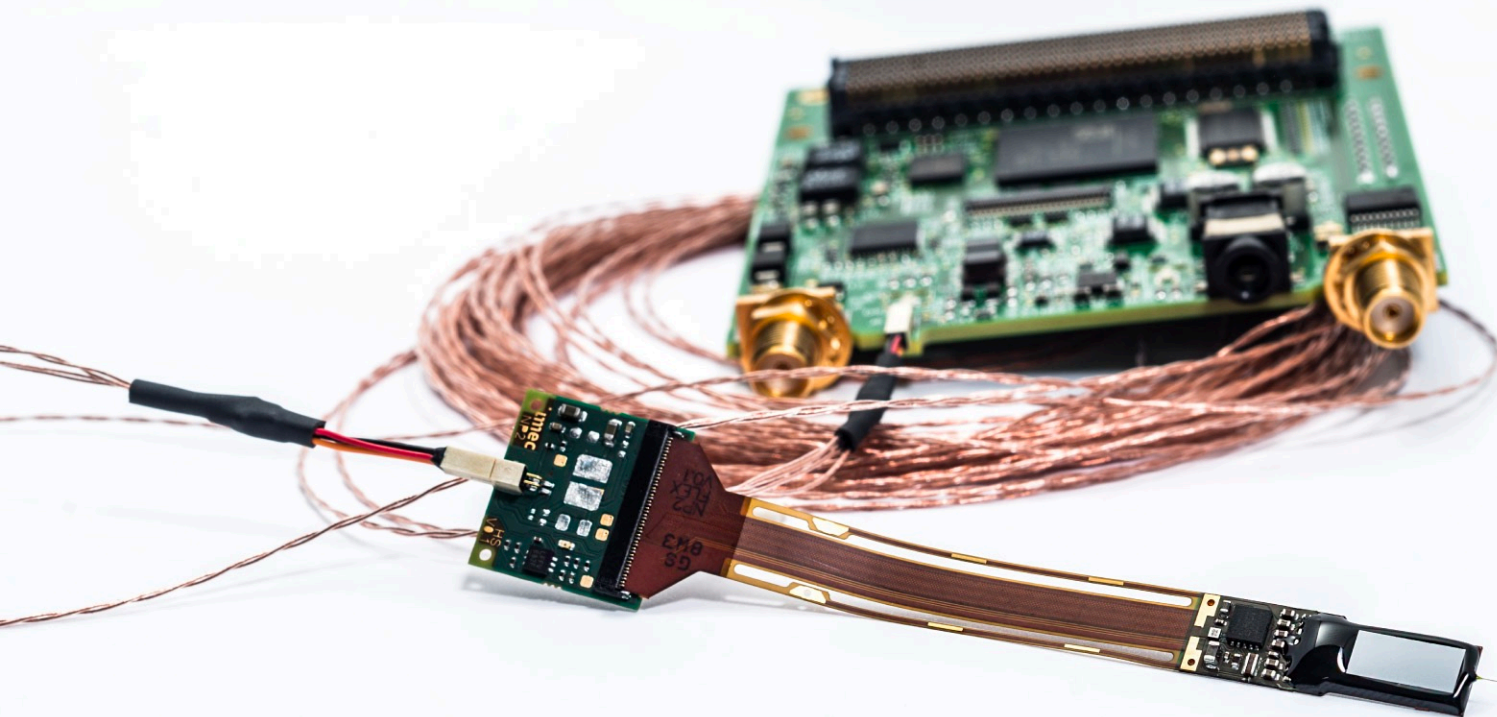

1 cm
20x70 micron
960 sensors

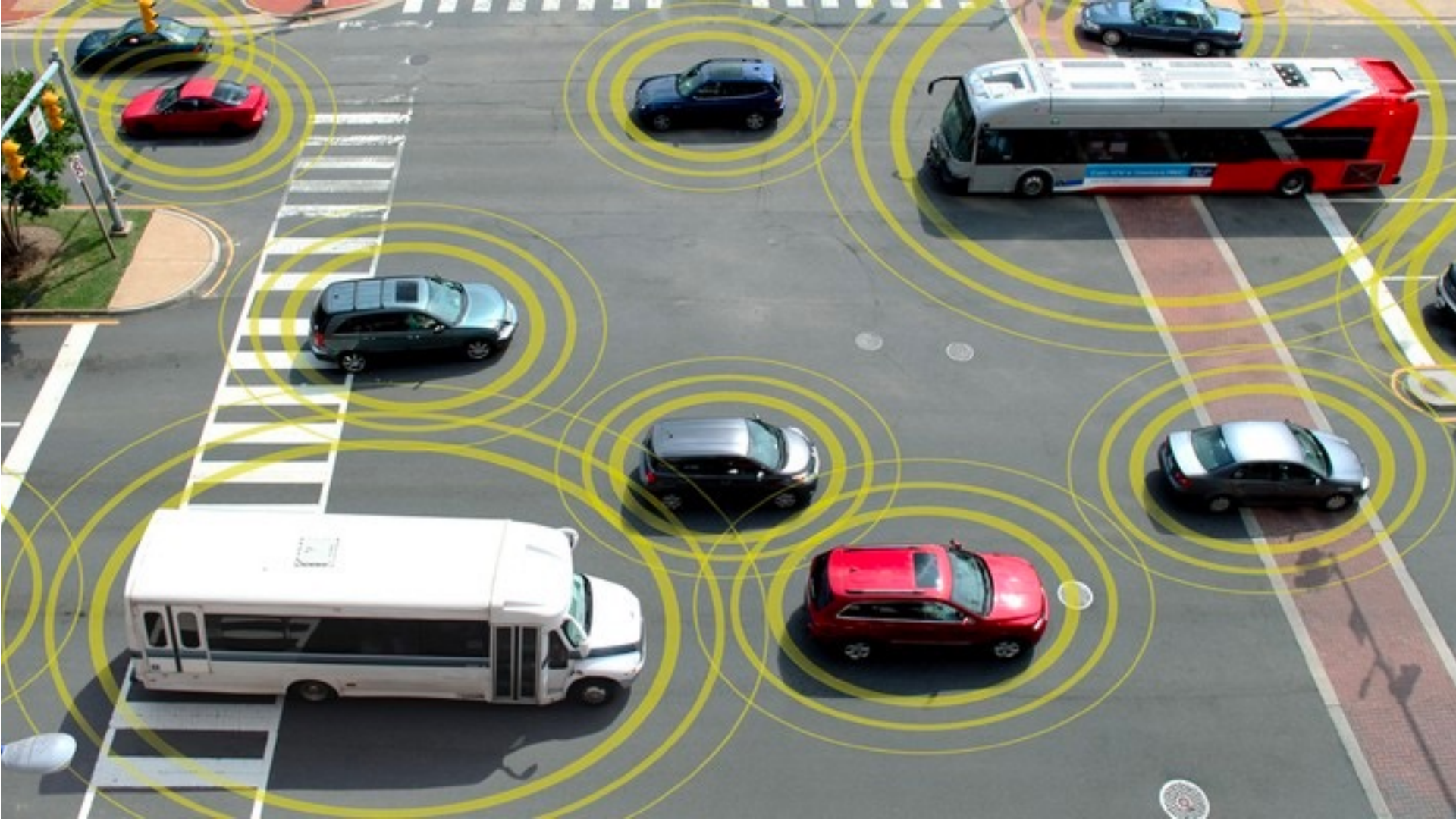

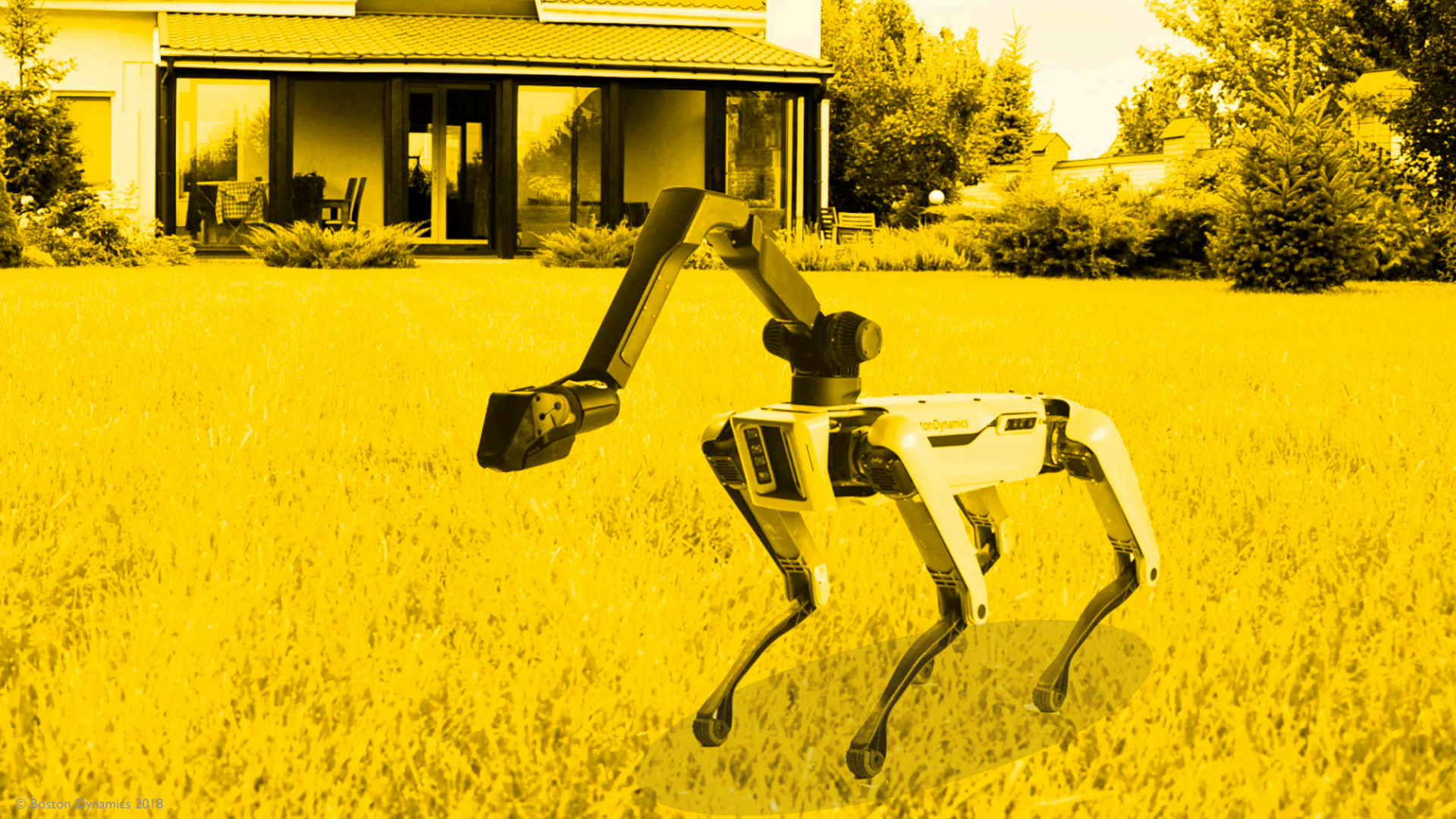

tonDynamics

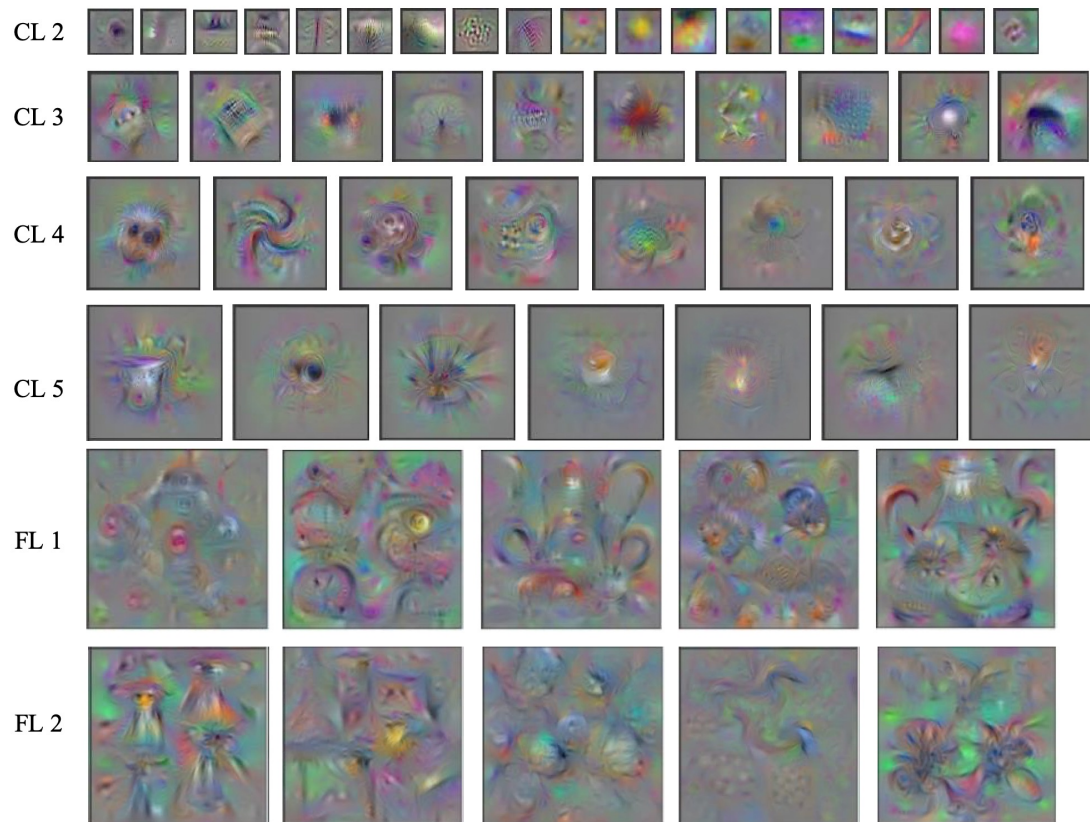

FIGURE 5. Hidden layers of *CaffeNet* visualization by *Activation Maximization*. Adapted from "Understanding Neural Networks Through Deep Visualization," by J. Yosinski, 2015.

TreeWatchWUR (@TreeWatchWUR) x +

twitter.com/treewatchwur?lang=en

Imported From Sa... imec B-Funding 18-19 Personal Attic Spotify Files - OneDrive Other Bookmarks

Home About Search Twitter Have an account? Log in



TreeWatchWUR
@TreeWatchWUR

I am the huge (popular) poplar tree ($\varnothing = 95.8$ cm) standing near the café The Spot in Orion at the Wageningen Campus in the Netherlands.

Wageningen, Nederland
treewatch.net
Joined May 2017
6 Photos and videos

Tweets 1,343 Following 5 Followers 4,425 Likes 11 Follow

Tweets Tweets & replies Media

TreeWatchWUR @TreeWatchWUR · Aug 12
Here is today's summary: shrunk 0 mm, transported 0 L of water at a maximum sap flow of 0 L/h.
3 7

TreeWatchWUR @TreeWatchWUR · Aug 11
Yesterday I've transported 0 L and today 0 L. My stomates are being regulated quite well.
1 10

TreeWatchWUR @TreeWatchWUR · Aug 10
Today I have shrunk 0 mm, transported 0 L of water at a maximum sap flow of 0 L/h.

The continuing thirst for sharing

5 key assumptions

1. More non-people than people connected.
2. Human bandwidth needs will no longer be the driver in access networks.
3. Symmetry needs will increase and break economics.
4. (Energy cost) of displaying information will eventually disappear
5. Cost of processing locally vs. cost of transmitting will not be clear-cut.

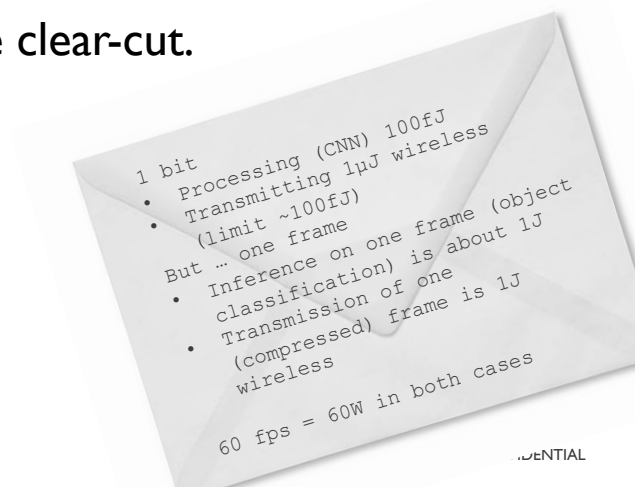

1 bit

- Processing (CNN) 100fJ
- Transmitting 1 μ J wireless (limit ~100fJ)

But ... one frame

- Inference on one frame (object classification) is about 1J
- Transmission of one (compressed) frame is 1J wireless

60 fps = 60W in both cases

“Value”

Does a shift make sense?

Current paradigm: data-center-centric.

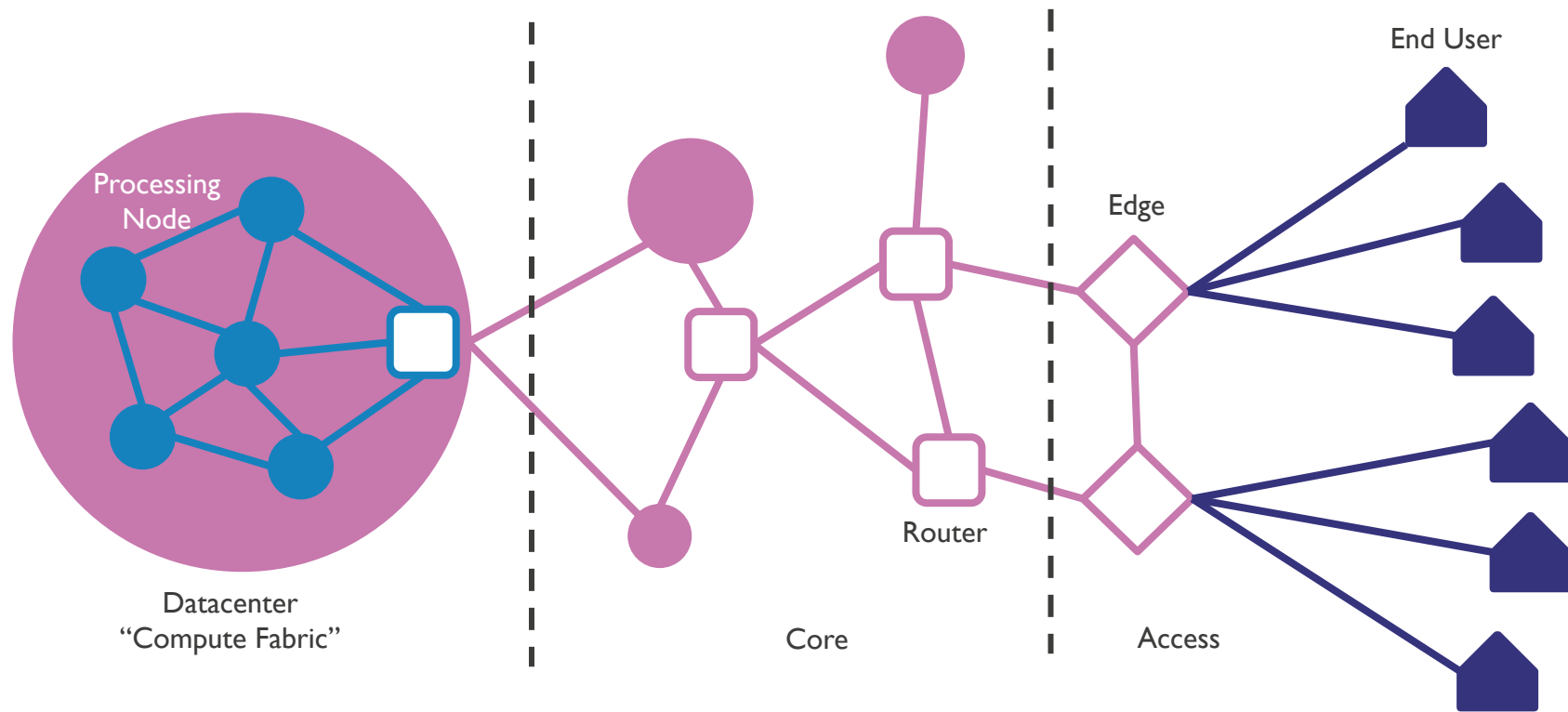

Does a shift make sense?

Future paradigm: agent-centric

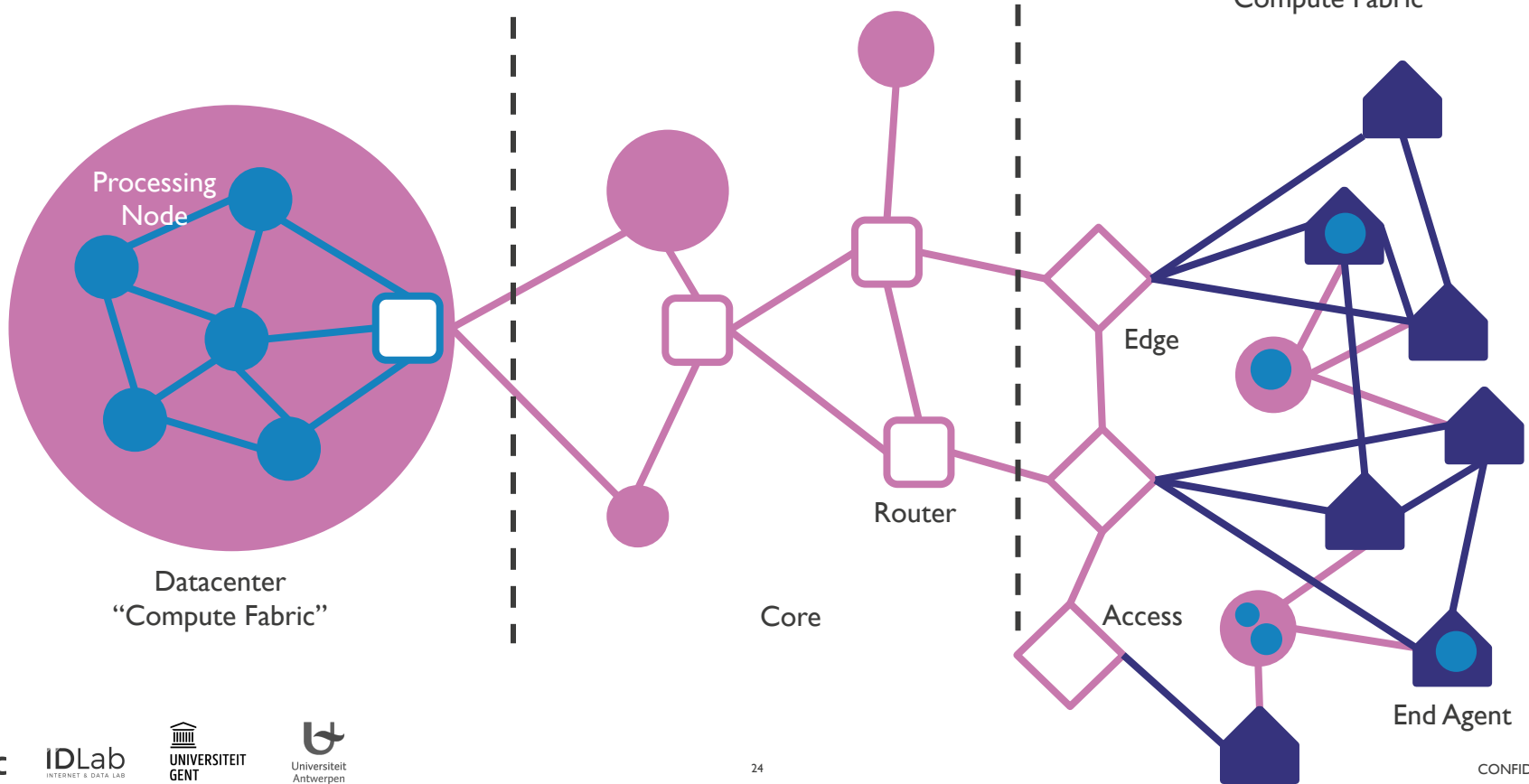

Time sensitive networking

Scheduling for industrial & meshed applications

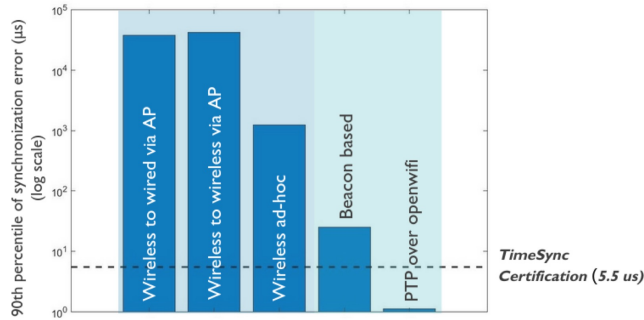

+ =

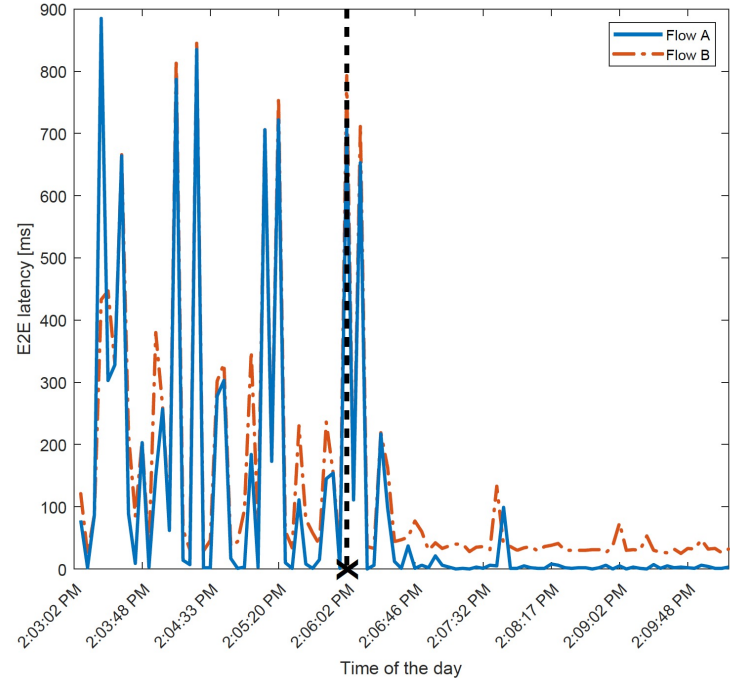
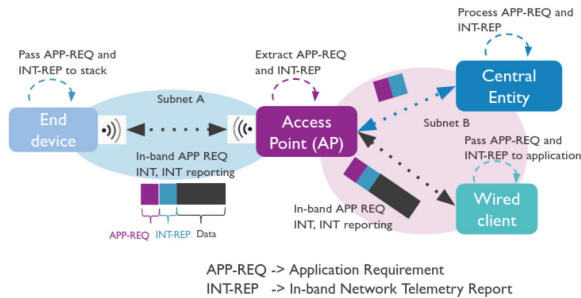

Location sensitive networking

Orchestration for mobile applications

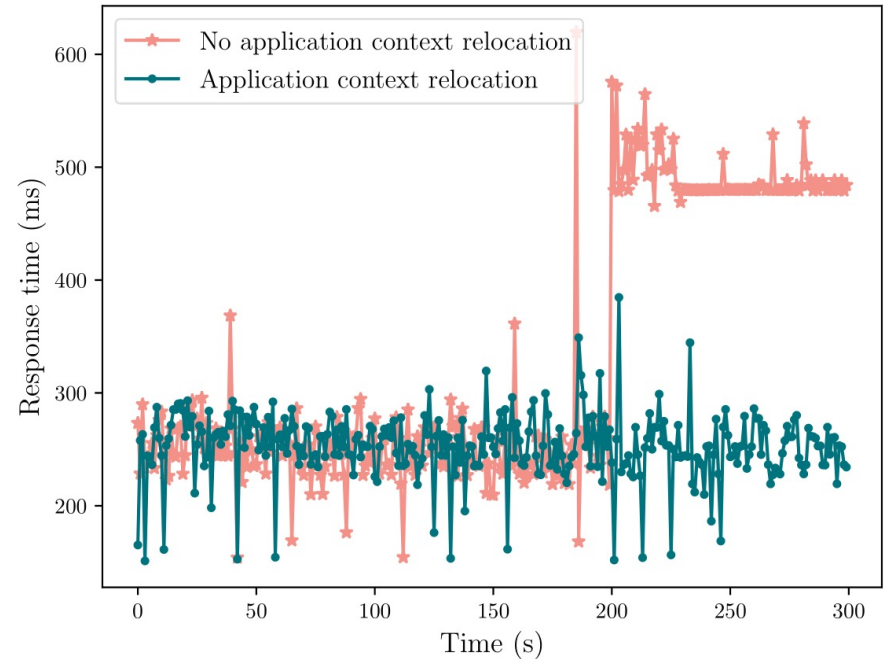
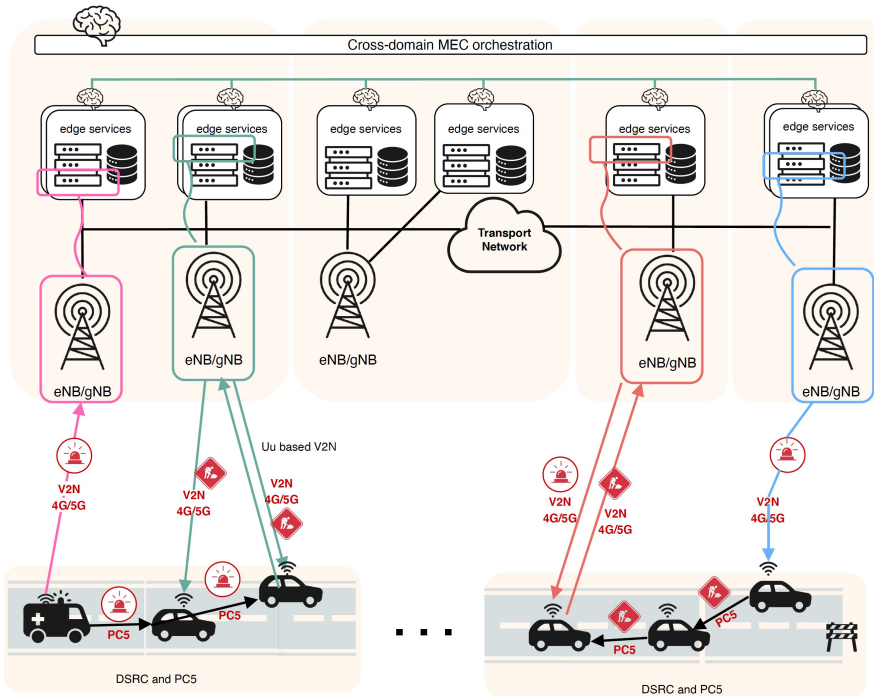

Graph Neural Networks

Naturally suited for performance prediction in dense shared networks

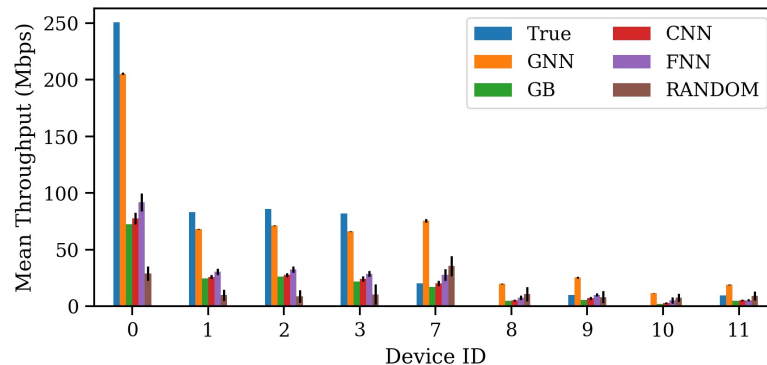
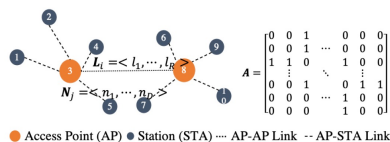
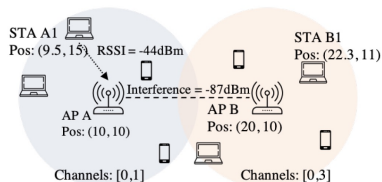
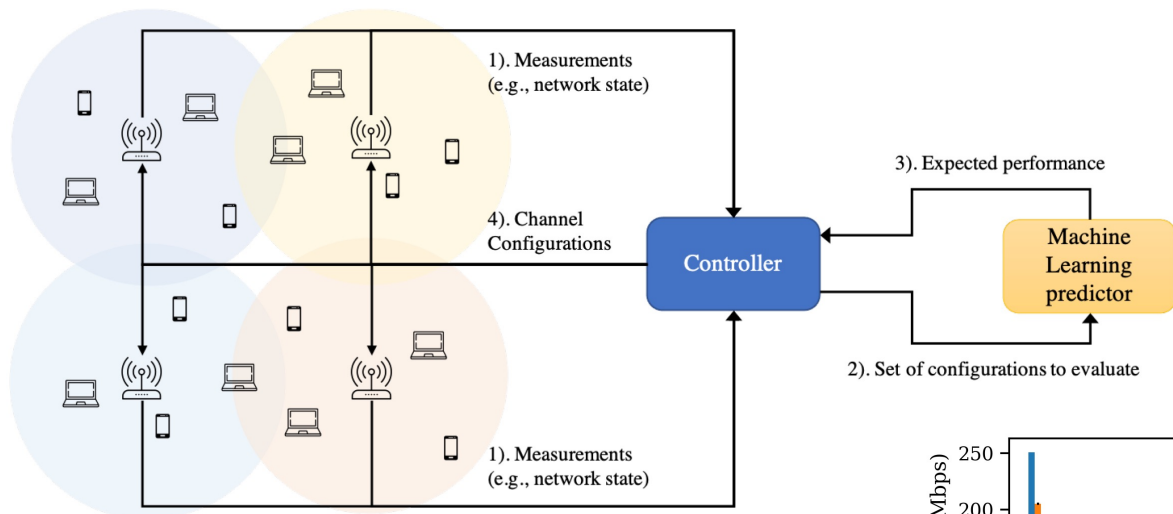

Terahertz

Rounding up

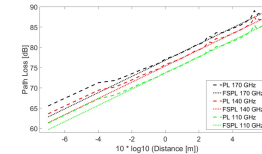

| Communication perspective | sub 7 | cmWave | mmWave | unlicensed mmWave | beyond 100, subTHz | THz |
|---------------------------|-------------------------------|-------------------------------|---------------------|------------------------------------|--|----------------|
| Typical carrier frequency | 3.5 GHz | 11 GHz | 28 GHz | 60 GHz | 140 GHz | >500 GHz |
| Typical bandwidth | 100 MHz | 200 MHz | 400 MHz | 2 GHz | 10 GHz | >10 GHz |
| Wavelength | 8.6 cm | 3 cm | 1 cm | 5 mm | 2.1 mm | < 1mm |
| Antennas on 1.5 x 1.5 cm | 0 | 1 | 9 | 36 | 196 | oodles |
| | RF sampling (m)MIMO GaN | No man's land (for mobile) | Beamforming CMOS | Hybrid BF P_{out} , PAE drops | Baseband \equiv RF Packaging III-V | P_{out} , NF |

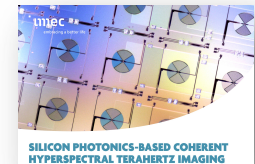

The next generation of wireless communications

x10 Higher throughputs

By exploiting wide bandwidths > 100GHz

x2 Higher energy efficiency significantly below 1nJ/bit

By exploiting wide channel bandwidths > 5GHz

Using III-V/III-N combined with advanced CMOS

x2 Smaller footprint

Following $\lambda/2$ antenna pitch (1.1mm)

Enabled by novel 2.5D/3D heterogeneous integration

Low-cost and path to mass-production

High speed III-V/III-N RF devices using low-cost, high-volume Si compatible processes, modules and toolsets

New low-cost integration approaches

Scalable / Modular beamforming

Addressing mobile and infrastructure applications

Addressing short (<5m) and longer range (>100m) applications

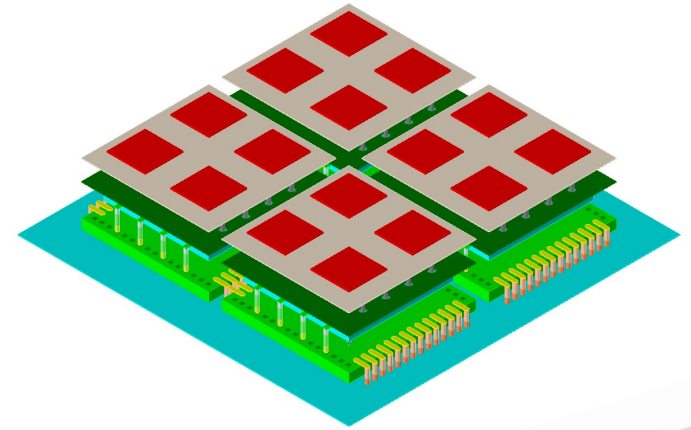

Achievable power and form factor

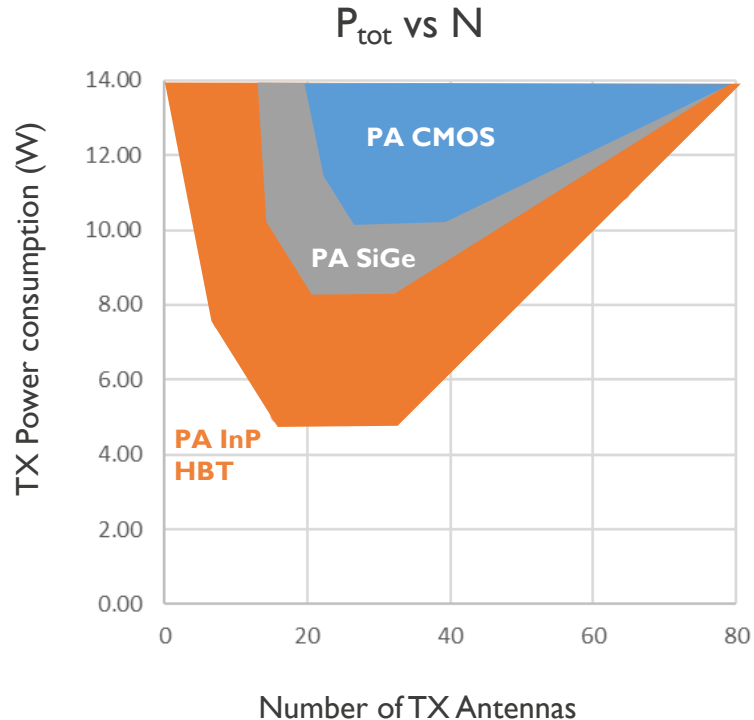

System study shows:

- Power and form factor constraints for user equipment >100GHz only achievable with InP

But requires:

- The need for a mature and cost-efficient InP technology to cope with mass-market demands
- Requires integration with CMOS – InP can not do it alone!

Achievable power and form factor

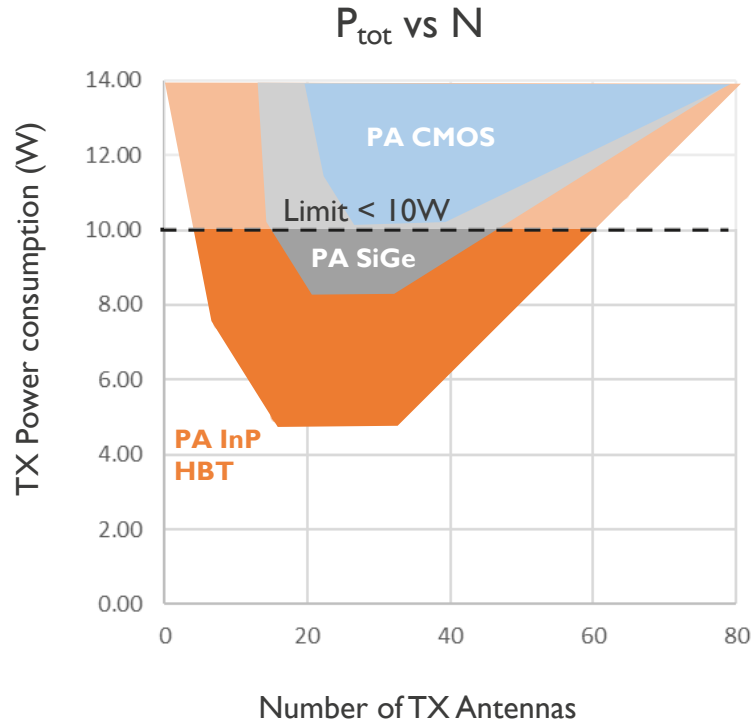

System study shows:

- Power and form factor constraints for user equipment >100GHz only achievable with InP

But requires:

- The need for a mature and cost-efficient InP technology to cope with mass-market demands
- Requires integration with CMOS – InP can not do it alone!

Achievable power and form factor

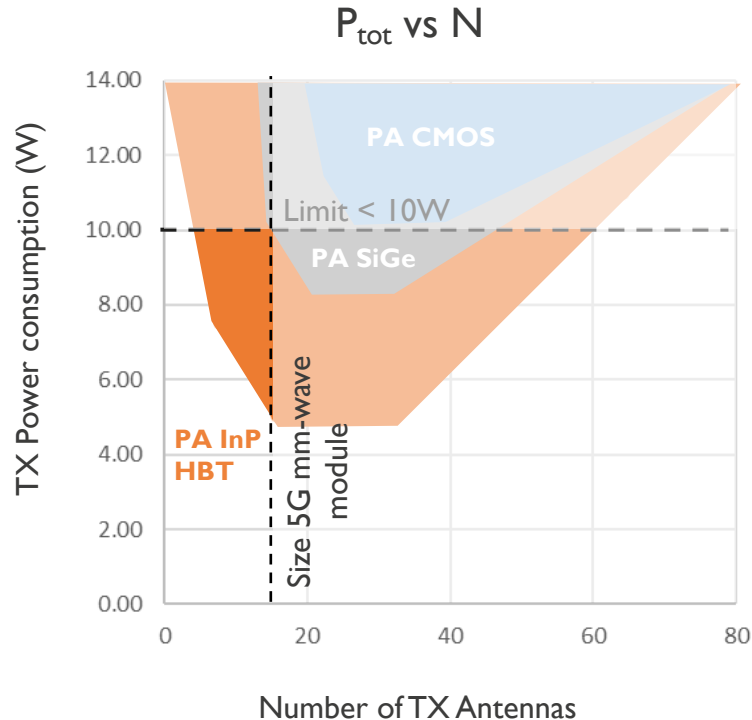

System study shows:

- Power and form factor constraints for user equipment >100GHz only achievable with InP

But requires:

- The need for a mature and cost-efficient InP technology to cope with mass-market demands
- Requires integration with CMOS – InP can not do it alone!

Mature and cost-efficient InP technology

Nano-ridge engineering:

- Direct selective growth of InP on Si
- Nano-ridge engineering for defect reduction

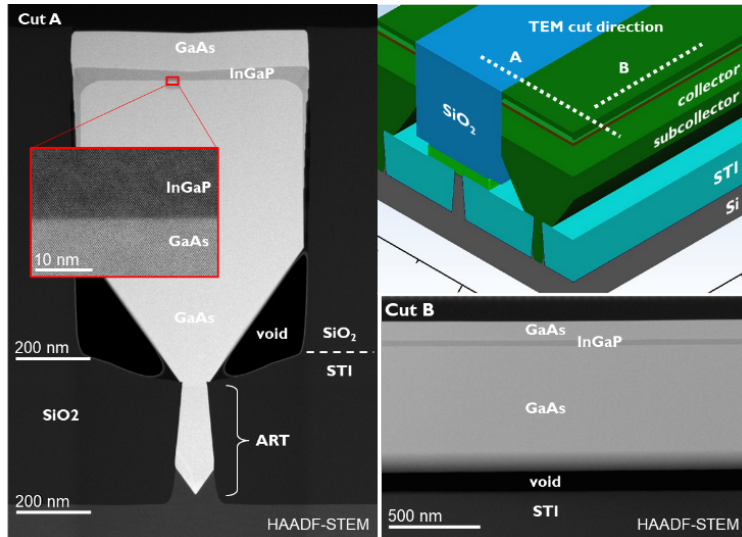

GaAs HBT demonstration: A. Vais et al, IEDM 2019.

Wafer reconstitution:

- InP tile reconstitution on 200/300mm Si wafer
- Starting from small size InP substrates

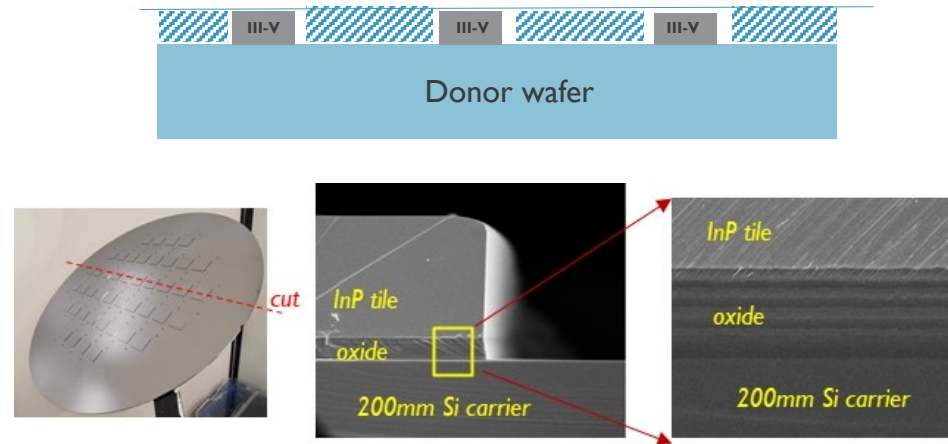

Courtesy: G. Karve & P. Soussan

InP + CMOS heterogeneous integration

> 100GHz beamforming transmitter

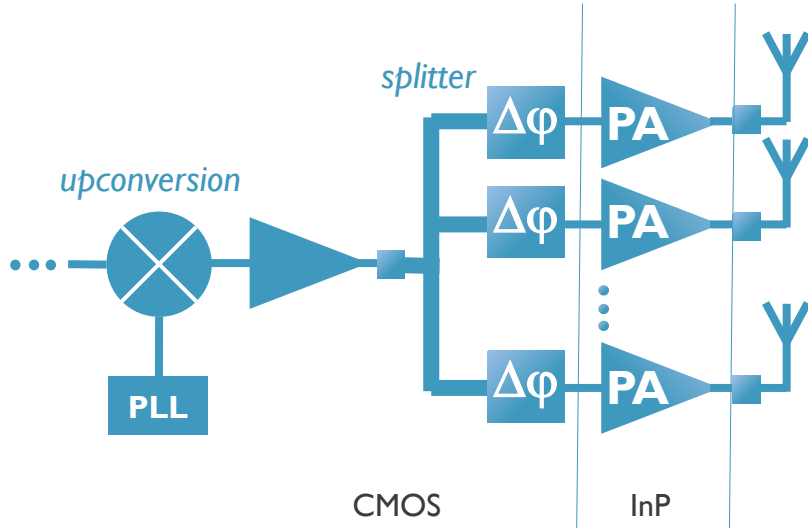

Several InP/CMOS integration options under investigation

State-of-the-art PCB (reference)

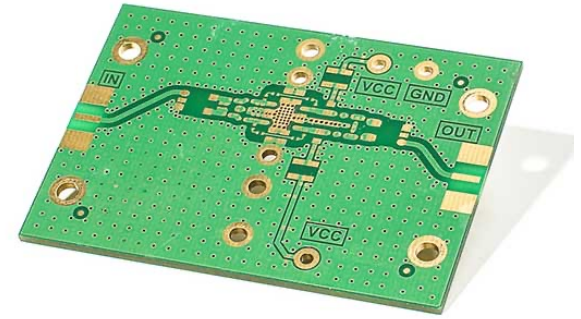

RF interposer

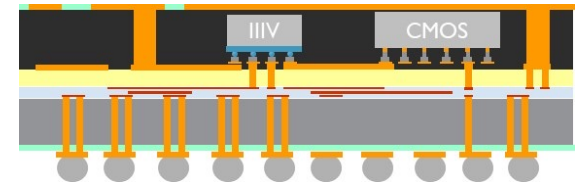

Wafer-level integration

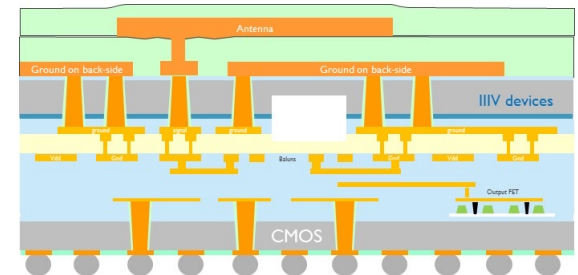

At higher frequencies

Everything becomes a trade-off

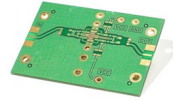
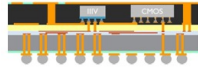

| Technology Type | Waferscale RF-Interposer | IC Substrate ("scaled PCB") | Standard PCB | Standard PCB + dielectric "cavity" | Standard PCB + cavity |
|---------------------|--------------------------|-----------------------------|----------------------------|------------------------------------|---|
| Line Type | Microstrip, Stripline | Microstrip, Stripline | Microstrip, Stripline, CPW | Substrate Integrated Waveguide | Air-Filled Substrate Integrated Waveguide |
| Typical Trace | 5 μm | 20 μm | 100 μm | 1000 μm | 1600 μm |
| Line Loss @ 150 GHz | 0.5 – 1 dB/mm | 0.3 – 0.5 dB/mm | 0.2 – 0.3 dB/mm | 0.15 dB/mm | 0.03 – 0.05 dB/mm |

Reference

ADC State of the art – what can we expect?

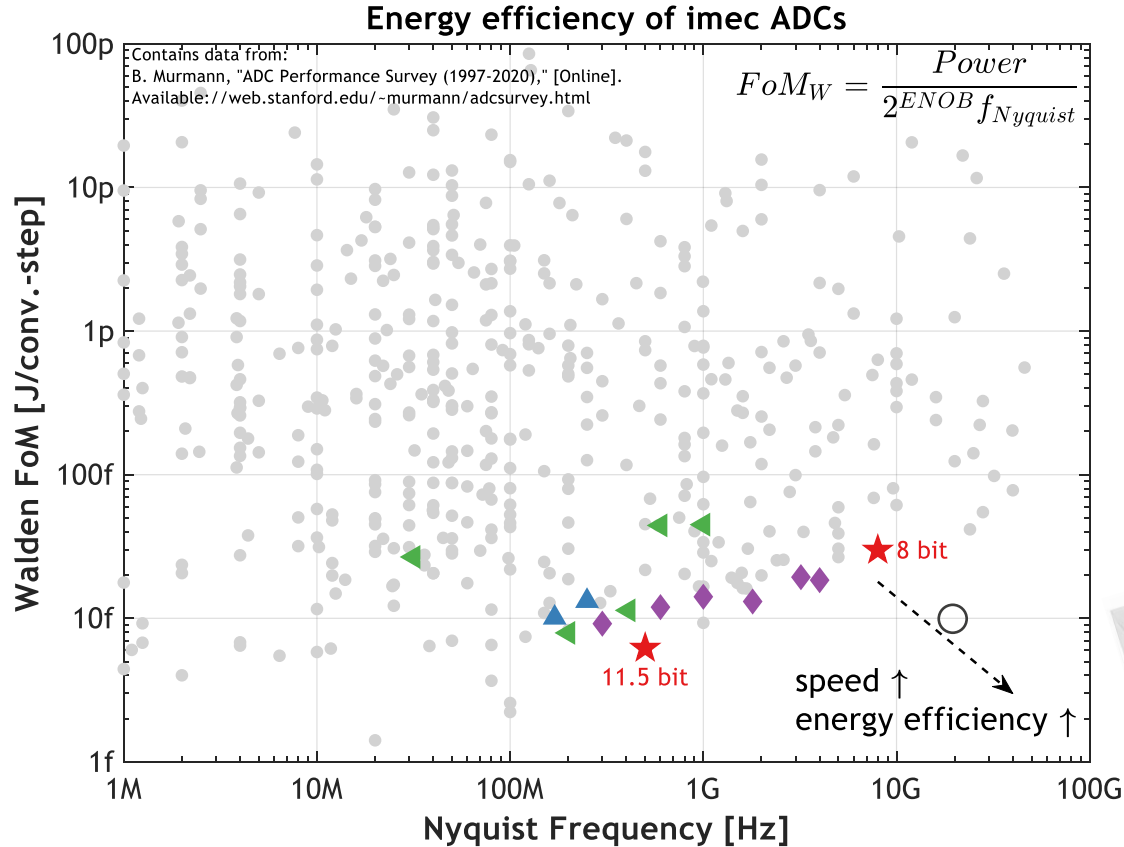

- Published designs
ISSCC/VLSI 1997-2020
- imec designs**
- ▲ 40nm ADCs
- ▼ 28nm ADCs
- ◆ 16nm ADCs
- ★ 16nm ADCs 2021



Usecases

Old and New



Hotspot



FWA



xHaul



D2D



XR



Edge AI/2AI

Other Applications

Convergence of communication and sensing

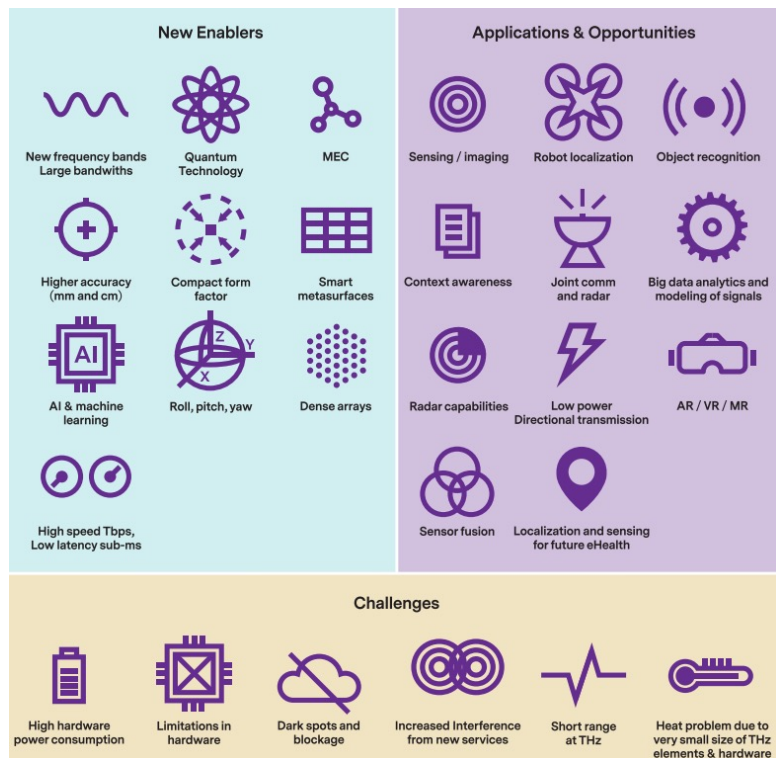

in-market

| | Macro | Micro |
|---------|---|------------------------------------|
| Comms. | 2026 High Capacity Wireless "6G" ("5.5G") | >2030 Nanonetworking |
| | | |
| Sensing | Radar Non-destructive testing | Spectroscopy Molecular analysis |
| | 2023 | 2026 |

Blocked Beams

Already in use today

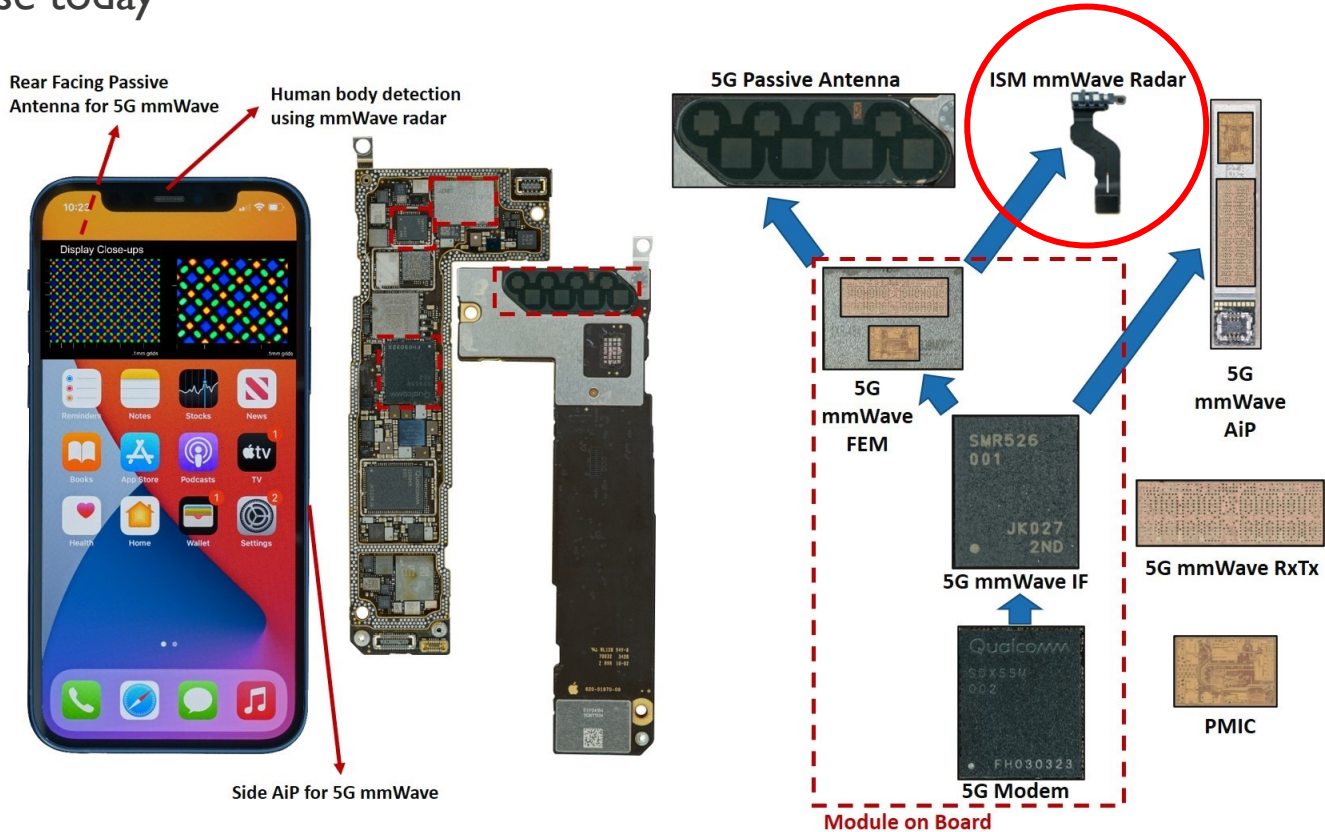

The medium is the message

I apologize...

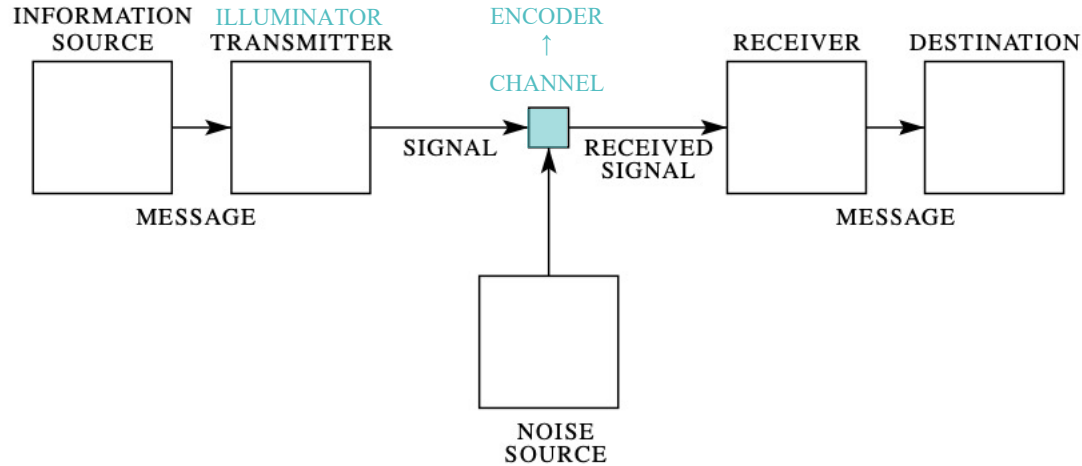

Fig. 1 — Schematic diagram of a general communication system.

PMCW radar equivalence: with r =received, s =sent, we see that we can either estimate s if the channel H is known (comms) or estimate h if the waveform matrix S is known (sense).

$$\underline{r} = \underline{H}^c \underline{s} = \underline{S}^c \underline{h}$$

Can we do better?

Opportunistic use of remainder after full-duplex cancellation

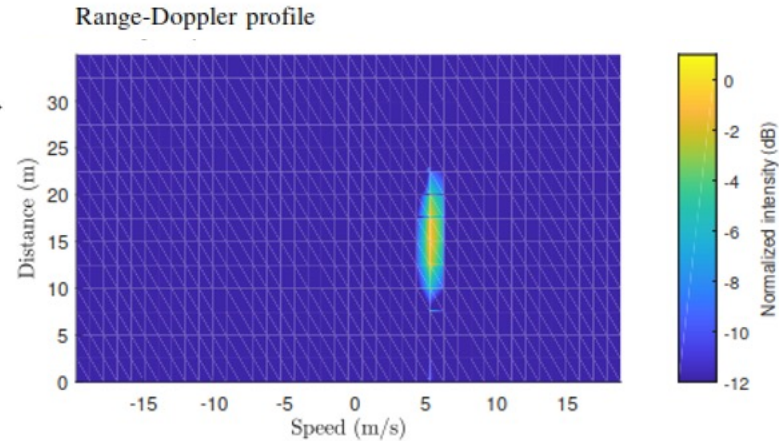
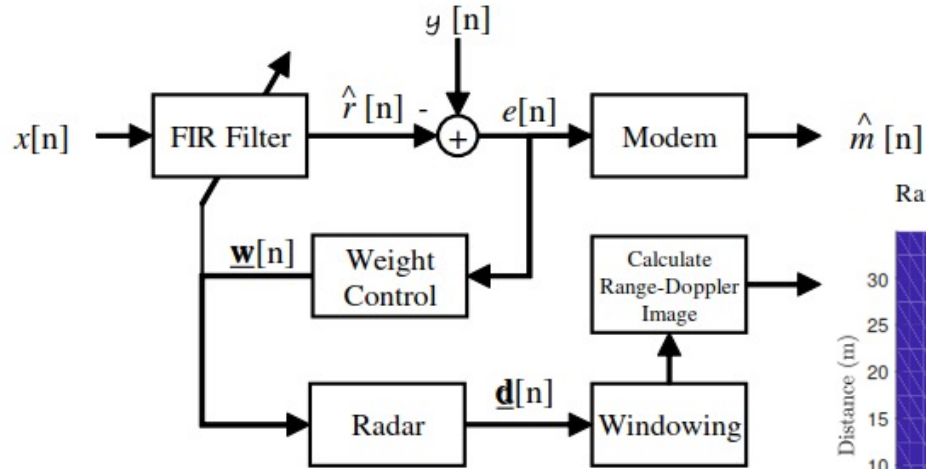

Experimental results

- 20MHz OFDM Communication signal
- Electrical balance duplexer for Tx-Rx isolation; 44 dB
- Single target at 15 m
- Offline radar processing by a 15-tap adaptive filter

How does this translate to “sensing”

Raw numbers

Table 1: Popular physical layers used in localization [36].

| Physical layer | Bandwidth | Raw resolution |
|-------------------------------|-------------------|-----------------------|
| IEEE 802.11a/g | 20 MHz | 15 m |
| IEEE 802.11n | 40 MHz | 7.5 m |
| IEEE 802.11ac | <160 MHz | >1.9 m |
| Ultra WideBand (UWB) | >500 MHz | <0.6 m |
| IEEE 802.11ad | >2 GHz | <15 cm |
| Terahertz - macroscale | >10 GHz | <3 cm |
| Terahertz - nanoscale | >1 THz | <0.3 mm |

Compute

From Design-Technology to System-Technology CO-optimization

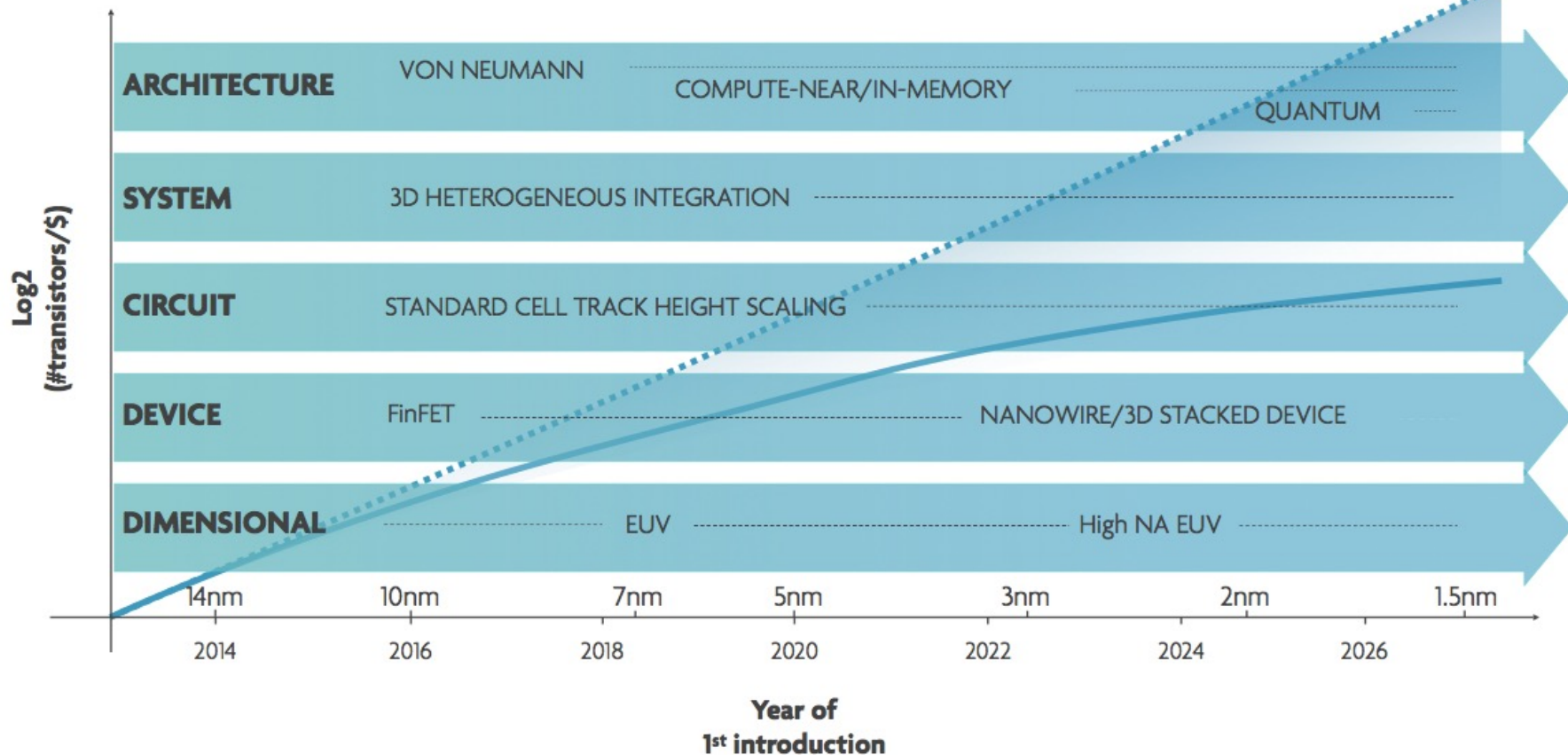

Communications

From Design-Technology to System-Technology CO-optimization

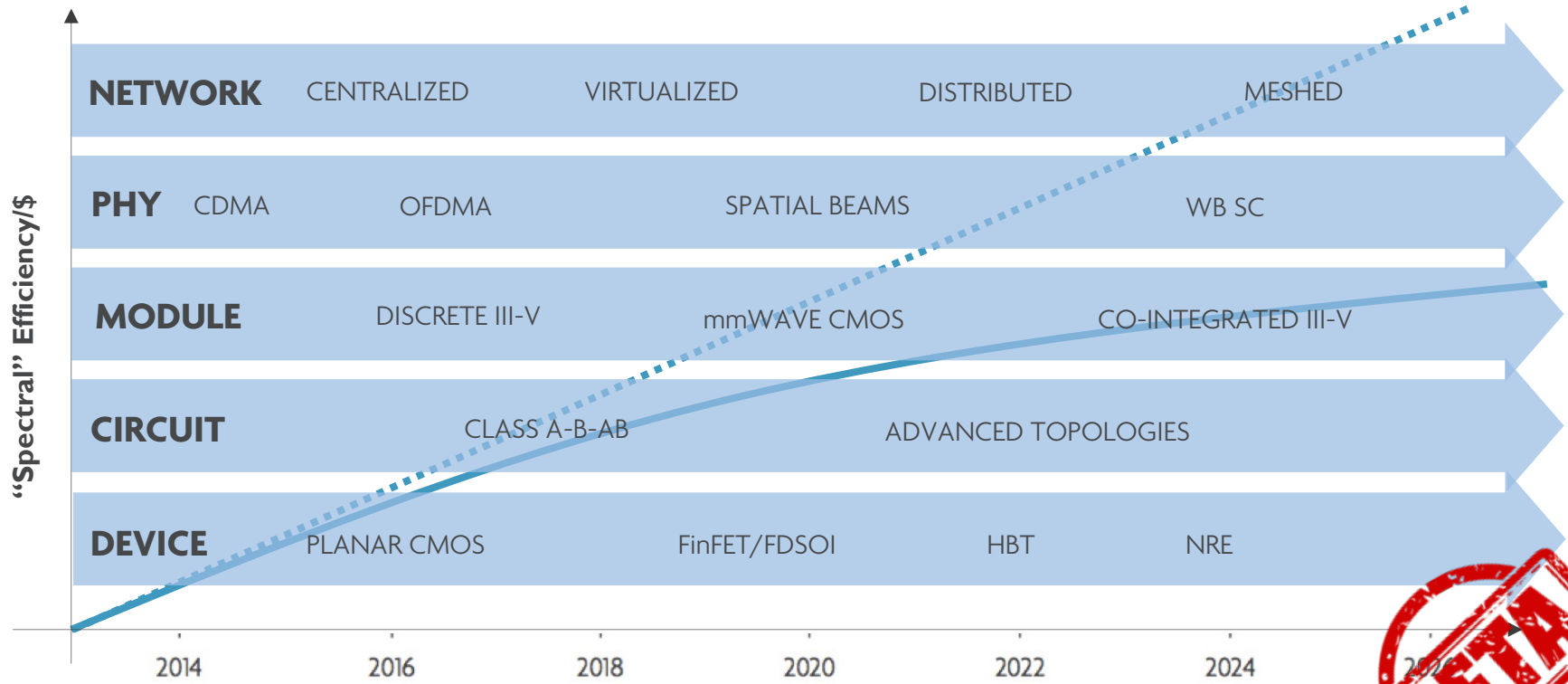



≡ **Call to Collaborate**



≡ **Call to Collaborate**





imec

embracing a better life

All errors are mine, all credit goes to the great work of the teams
from imec Leuven, imec Florida, imec Eindhoven, IDLab UAntwerpen,
IDLab UGent, ESAT KUL and ETRO VUB

