

EUCNC | 6G Summit

Poznan, Poland ▪ 3-6 June 2025

Towards the 6G World

www.eucnc.eu



Exhibitors Guidelines

EXHIBITION IN EUCNC 2025 & 6G SUMMIT

The 2025 European Conference on Networks and Communications & 6G Summit builds on putting together two successful conferences: EuCNC, in its 34th edition of a series, supported by the European Commission; the 6G Summit, in its 7th edition, originated from the 6G Flagship programme in Finland, one of the very first in its area. The conference is sponsored by the IEEE Communications Society (ComSoc), the European Association for Signal Processing (EURASIP) and the European Association on Antennas and Propagation (EurAAP). The conference addresses various aspects of Beyond 5G/6G communications systems and networks. It brings together cutting-edge research and world-renown industries and businesses, globally attracting in the last years close to 1 000 delegates from more than 40 countries all over the world, to present and discuss the latest results, and an exhibition with more than 50 exhibitors, for demonstrating the technology developed in the area, namely within research projects from EU programmes.

In parallel to the events, there will be a major exhibition, extending for the entire main conference days, from June 3rd to June 6th, presenting a wide range of technologies, products and results from European Commission co-funded projects. Prominent research institutions, SMEs, as well as large industries from Europe and other parts of the world will be showcasing at EuCNC & 6G Summit.

TABLE OF CONTENTS

CALL FOR EXHIBITIONS AND DEMOS.....	3
Important Details:.....	3
CALL FOR POSTER BOOTHS.....	4
Important Details:.....	4
Registration:	4
CALL FOR SMEs DEMOS.....	5
Important Details:.....	5
Registration:	5
CALL FOR UNIVERSITIES DEMOS.....	6
Important Details:.....	6
Registration:	6
CALL FOR PITCHES	8
Important Details:.....	8
Presentation:	8
Registration:	8
CONFERENCE VENUE.....	9
Venue Address.....	10
Entrance.....	10
Accessibility	11
DATES & TIMING.....	12
EXHIBITION	13
Installation of the booths	13
Removal of the booths	14
BOOTHS	15
Regular Booth.....	15
Small Booth.....	16
Poster Booth.....	17
Additional Equipment.....	18
Electricity	18
Access and Registration.....	18
DELIVERIES.....	20
Pre-Congress Deliveries.....	20
Direct deliveries.....	20
GENERAL RULES & DISCLAIMERS.....	22
TERMS OF PAYMENT	23

CALL FOR EXHIBITIONS AND DEMOS

Exhibitions and Demos proposals are invited in all Tracks:

- PHY - Physical Layer and Fundamentals
- WOS – Wireless, Optical and Satellite Networks
- NET – Network Softwarisation
- AIU – Applications, IoT, Use cases
- OPE – Operational & Experimental Insights
- AI4C – AI/ML Solutions for Communications
- SAQ – Security Aspects and Quantum Communications
- CMP – Components, Microelectronics & Photonics
- NVS – Next-Generation Visions & Sustainability

Exhibitions and Demos may address one or more Tracks, but they should be organised under a unified theme. Exhibitions and Demos are expected to show the demonstration of novel technologies and their application.

Exhibition booths of 6 m² or 12 m² will be located in the main hall where coffee and lunch breaks will be held, and are supposed to have at least one person present, at least during breaks, in order to present the demonstration to attendees.

Exhibitions and Demos will extend for the entire main conference days.

Important Details:

The proposal must be submitted until the deadline on **2025 Mar. 28**.

Exhibitions and Demos proposals should be submitted via the dedicated Online Form – <https://forms.gle/61MuQawttmHx5Gdg7>. Proposers should provide information on the Title, Objective, Motivation and Background, Description, and associated Requirements.

In case of any problems with online form submission, please contact [Exhibition Co-Chairs](#).

Exhibitors can also apply for a Pitch at the Speakers Corner, to be held during coffee breaks, via the dedicated Online Form - <https://forms.gle/4tCBss5ju5JUy7548>.

Exhibitions and Demos proposals will be evaluated according to the following criteria:

- Relevance
- Timeliness
- Technical content
- Novelty
- Overall Recommendation

A Best Demo Award will be issued.

Registration:

An exhibitor conference registration (R-5-E – *Exhibitor Conference Registration*) is included in the fee paid for the exhibition, for 1 or 2 persons, respectively for 6 m² or 12 m² booths.

CALL FOR POSTER BOOTHS

Poster Booth proposals are invited in all Tracks:

- PHY – Physical Layer and Fundamentals
- WOS – Wireless, Optical and Satellite Networks
- NET – Network Softwarisation
- AIU – Applications, IoT, Use cases
- OPE – Operational & Experimental Insights
- AI4C – AI/ML Solutions for Communications
- SAQ – Security Aspects and Quantum Communications
- CMP – Components, Microelectronics & Photonics
- NVS – Next-Generation Visions & Sustainability

Poster Booths may address one or more Tracks, but they should be organised under a unified theme. Poster Booths are expected to show posters addressing novel technologies and their application. Poster Booths will enable projects, research teams and other researchers to show their early stage work.

Poster Booths will be in dedicated poster walls located in the main hall where coffee and lunch breaks will be held, and are supposed to have at least one person present, at least during breaks, in order to present the posters to attendees.

Poster Booths will extend for the entire main conference days.

Important Details:

The proposal must be submitted until the deadline on **2025 Mar. 28**.

Poster Booths proposals should be submitted via the dedicated Online Form – <https://forms.gle/1h6S29SREVFfGTeG9>. Proposers should provide information on the Title, Objective, Motivation and Background, and Description.

In case of any problems with online form submission, please contact [Exhibition Co-Chairs](#).

Poster Booths proposals will be evaluated according to the following criteria:

- Relevance
- Timeliness
- Technical content
- Novelty
- Overall Recommendation

A Best Poster Booths Award will be issued.

Registration:

Conference registration is not included in the fee paid for the booth, and the presenter is required to register with either *R-1-F – Full* or *R-2-L – Limited* registration levels, each Poster Booth being required to be associated to one registration (which cannot cover more than one of these booths).

CALL FOR SMEs DEMOS

SMEs Demos proposals are invited in all Tracks:

- PHY – Physical Layer and Fundamentals
- WOS – Wireless, Optical and Satellite Networks
- NET – Network Softwarisation
- AIU – Applications, IoT, Use cases
- OPE – Operational & Experimental Insights
- AI4C – AI/ML Solutions for Communications
- SAQ – Security Aspects and Quantum Communications
- CMP – Components, Microelectronics & Photonics
- NVS – Next-Generation Visions & Sustainability

SMEs Demos are an opportunity for companies to show their products to the conference audience and beyond (i.e., via the conference communication activities, these demos will be shown to a wider audience). They can include demos from technical products and services, research projects, and collaborations with external partners (e.g., industrial or governmental), among others. This is an opportunity for companies to showcase demos and innovations to researchers worldwide as well as to industry leaders, increasing the visibility of their work and enabling networking around it.

SMEs Demos booths will be located in the main hall where coffee and lunch breaks will be held, and are supposed to have at least one person present, at least during breaks, in order to present the demonstration to attendees.

SMEs Demos will extend for the entire main conference days.

Important Details:

The proposal must be submitted until the deadline on **2025 Mar. 28**.

SMEs Demos proposals should be submitted via the dedicated Online Form – <https://forms.gle/rw4Uesy4DzKSfUocEA>. Proposers should provide information on the Title, Objective, Motivation and Background, Description, and associated Requirements.

In case of any problems with online form submission, please contact [Exhibition Co-Chairs](#).

SMEs Demos can also apply for a Pitch at the Speakers Corner, to be held during coffee breaks, via the dedicated Online Form - <https://forms.gle/4tCBss5ju5JUy7548>.

SMEs Demos proposals will be evaluated according to the following criteria:

- Relevance
- Timeliness
- Technical content
- Novelty
- Overall Recommendation

A Best SME Demo Award will be issued.

Registration:

One exhibitor conference registration (R-5-E – *Exhibitor Conference Registration*) is included in the fee paid for the booth.

CALL FOR UNIVERSITIES DEMOS

Universities Demos proposals are invited in all Tracks:

- PHY – Physical Layer and Fundamentals
- WOS – Wireless, Optical and Satellite Networks
- NET – Network Softwarisation
- AIU – Applications, IoT, Use cases
- OPE – Operational & Experimental Insights
- AI4C – AI/ML Solutions for Communications
- SAQ – Security Aspects and Quantum Communications
- CMP – Components, Microelectronics & Photonics
- NVS – Next-Generation Visions & Sustainability

Universities Demos are an opportunity for academics and students to show their work to the conference audience and beyond (i.e., via the conference communication activities, these demos will be shown to a wider audience). They can include demos from research projects, Ph.D. (and M.Sc.) theses, and collaborations with external partners (e.g., industrial or governmental), among others. This is an opportunity for research groups to showcase demos and innovations to researchers worldwide as well as to industry leaders, increasing the visibility of their work and enabling networking around it.

Universities Demos booths will be located in the main hall where coffee and lunch breaks will be held, and are supposed to have at least one person present, at least during breaks, in order to present the demonstration to attendees.

Universities Demos will extend for the entire main conference days.

Important Details:

The proposal must be submitted until the deadline on **2025 Mar. 28**.

Universities Demos proposals should be submitted via the dedicated Online Form – <https://forms.gle/DTTzZkTYuk6cxQsK9>. Proposers should provide information on the Title, Objective, Motivation and Background, Description, and associated Requirements.

In case of any problems with online form submission, please contact [Exhibition Co-Chairs](#).

Universities Demos can also apply for a Pitch at the Speakers Corner, to be held during coffee breaks, via the dedicated Online Form - <https://forms.gle/4tCBss5ju5JUy7548>.

Universities Demos proposals will be evaluated according to the following criteria:

- Relevance
- Timeliness
- Technical content
- Novelty
- Overall Recommendation

A Best University Demo Award will be issued.

Registration:

The booth registration is complimentary, but presenters have to register to the conference. A University Demo requires the presenter to register with full (R-1-F - Full Conference Registration) or limited (R-2-L -

Limited Conference Registration) registration level. Each University Demo requires to be connected to a single registration with the limitation on one booth per person.

CALL FOR PITCHES

The conference will host Exhibitions and Demos, Universities Demos, and SMEs Demos, for the entire main conference days, in the main hall where coffee and lunch breaks will be held, where, at least during the breaks, exhibitors will have the opportunity to interact with attendees.

In order to increase the visibility of all exhibitions and demos, exhibitors are given the opportunity to apply for a Pitch at the Speakers Corner, with a targeted duration of 5 minutes, to be held during breaks, therefore, having one more means to reach the audience. The Speakers Corner will have a screen, microphone and an elevated stage, so that speakers can share their views with the audience.

Important Details:

Exhibitors (from Exhibitions and Demos, Universities Demos, and SMEs Demos) can apply for a Pitch via the dedicated Online Form – <https://forms.gle/4tCBss5ju5JUy7548>.

The proposal must be submitted until the deadline on **2025 Mar. 28**.

In case of any problems with online form submission, please contact [Exhibition Co-Chairs](#).

Presentation:

Please provide your presentation as a .pptx or .PDF file, at least one week before the start of the conference to give to the organisers enough time to prepare the area and test the equipment. The presentation file should be submitted to exhibit.eucnc6gs@gmail.com.

Registration:

All participants in the Speakers Corner, regardless of the nature of their presentation, must pay the registration fee and have a booth in the conference.

CONFERENCE VENUE

Located in the middle of the Poznań fairgrounds, the Poznan Congress Center is a multifunctional, three-storey building with more than 4,000 conference seats, a VIP area and a space dedicated to exhibitors and sponsor stands. The building has 38 fully-equipped conference rooms with adjustable size and a spacious foyer with an area of 2,250 square meters, ideal for exhibitions and banquets.





Venue Address

Poznan Congress Center (PCC)

Głogowska Street 14,
60-748 Poznań, Poland

<https://poznancongresscenter.pl/en>

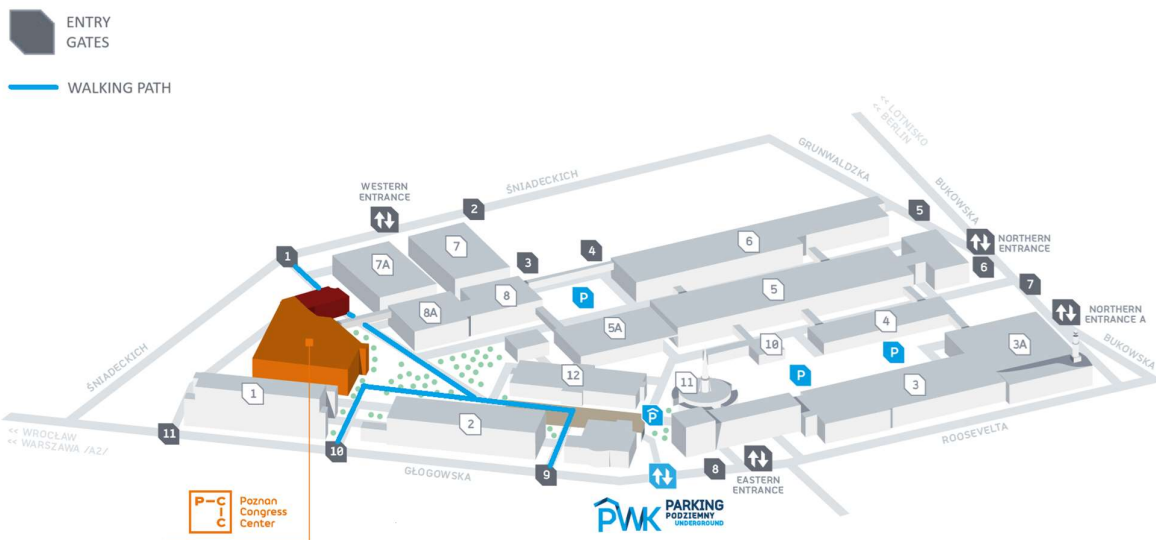

Entrance

The building has two different entrances (A and B). The entrance for the EuCNC 6G Summit is the Main Entrance (A).

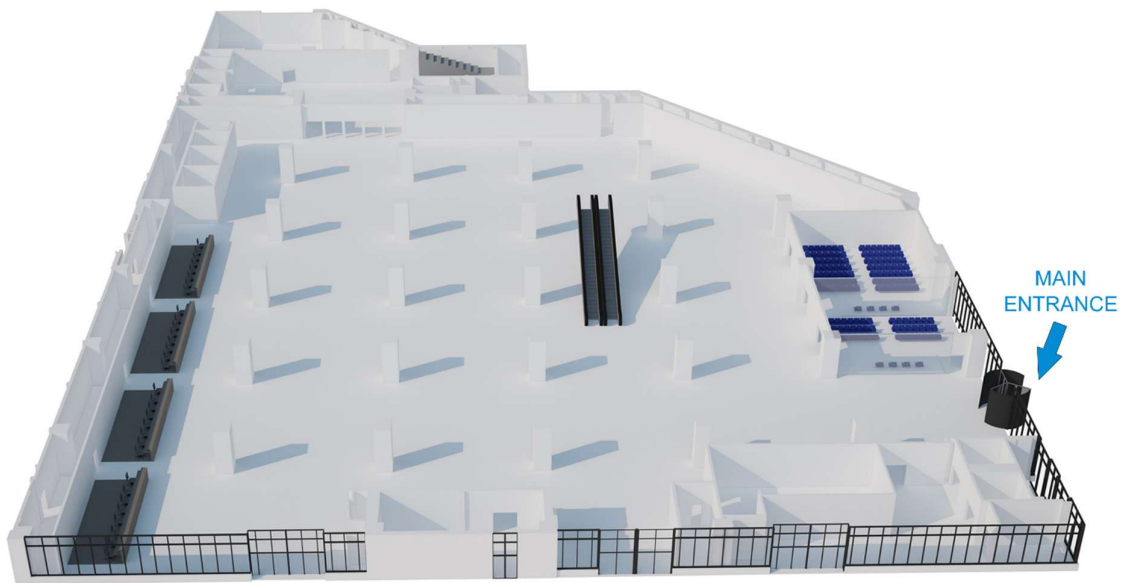

POZIOM / LEVEL 0

Accessibility

The Poznan Congress Center is located in the middle of the Poznań fairgrounds in the centre of the city of Poznań. It is within 2 minutes' walking distance of the Poznań Main Railway station (Poznań Główny).

Ławica Airport is located at a distance of 6 km from the fairgrounds, with the bus stop of the airport express bus located close to the northern entrance of the Poznań fairgrounds area.

The car park ([PWK](#)) Underground Parking is located at 11 Głogowska Street, on the premises of the Poznań International Fair. The entrance to the car park is located just behind the Trade Fair building, at the height of the railway station. It is open 24 hours a day and can accommodate 650 cars. It is open 24 hours a day and can accommodate 650 cars.

DATES & TIMING

Construction Period

Monday 2 June: from 18:00 to 21:00 hrs

Tuesday 3 June: from 8:00 hrs to 17:00 hrs

Exhibition Period

Tuesday 3 June - 18.00 – 21.00 hrs (Welcome Reception)

Wednesday 4 June: 08.00 – 17.30 hrs

Thursday 5 June: 08.00 – 17.30 hrs

Friday 6 June: 08.00 – 11.00 hrs

Deconstruction Period

Friday 6 June: from 11:00 to 15:00 hrs

All times are local time. Exact timeframes are tentative and will be updated at a later date.

EXHIBITION

The exhibition will take place on the ground floor (Level 0) of PCC. This area will also host Coffee breaks, lunches and the Welcome Reception. The schematic below presents the possible booths layout and organisation of the exhibition.

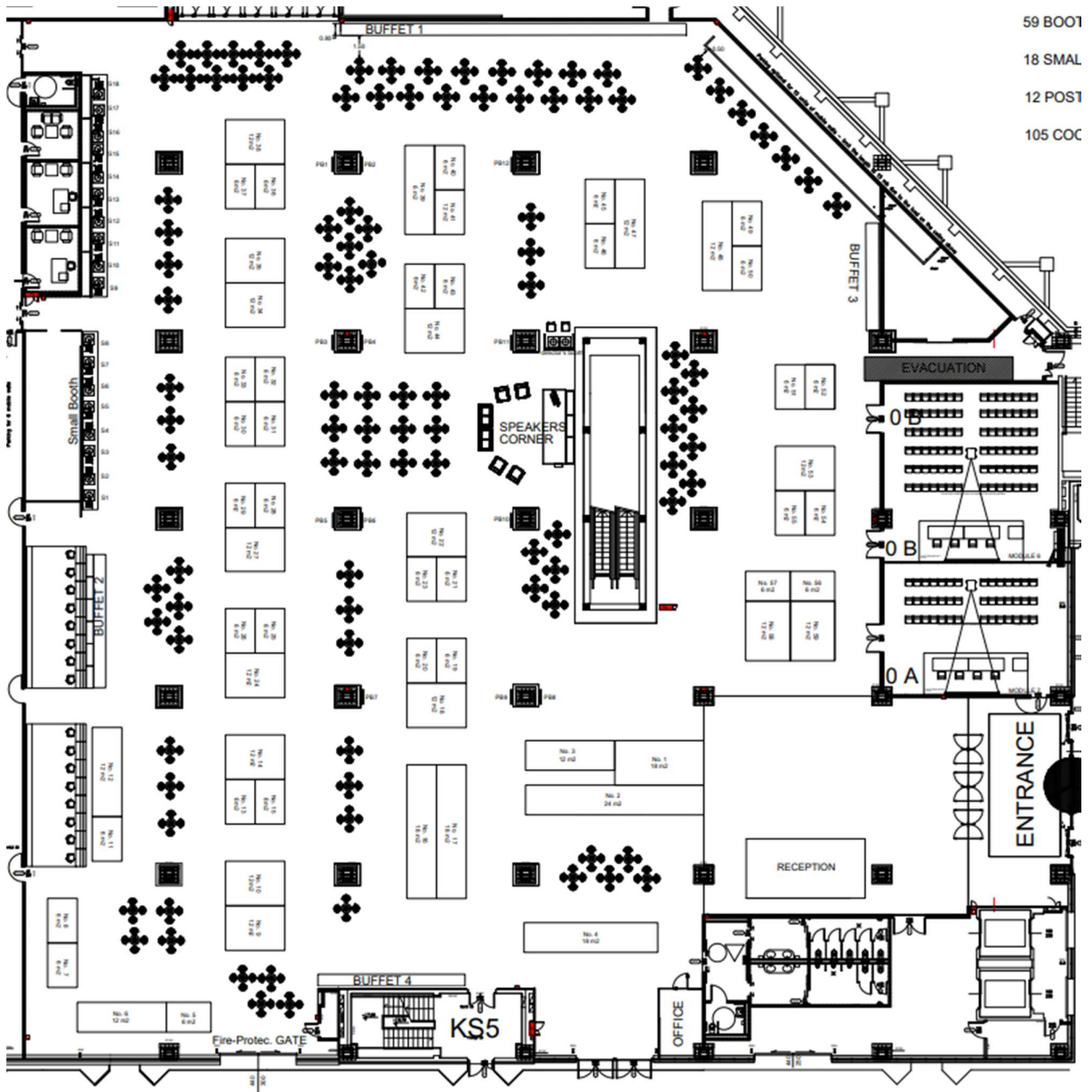

Installation of the booths

PCC staff will coordinate the set-up and dismantling of the exhibition and are at your service throughout the conference for any questions you may have.

Booth installation is set for Monday, 2 June and Tuesday, 3 June. On Monday starting at 18.00 hrs and concluding at 21.00 hrs, on Tuesday from 08:00 hrs until 17:00 hrs. All booths must be fully prepared by 17.00 hrs. Please be advised that booth construction is prohibited during the Welcome Reception, taking place in the exhibition hall at 18.00 hrs on Tuesday.

The exact booth location for your company will be decided later and indicated on the booth of the exhibition area.

Removal of the booths

PCC staff will coordinate the dismantling of the exhibition and are at your service throughout the conference for any questions you may have.

Booths are to be removed on Friday, June 6, immediately after 11.00 hrs until 15.00 hrs.

Booths may on no account be removed earlier or on another date. We urge you to respect the congress time schedule and to await the end of the congress to remove your booth.

IMPORTANT: Exhibitors must not leave any waste behind. All associated costs will be charged.

BOOTHS

Exhibition booths will be available at 2025 EuCNC & 6G Summit for projects, universities and research labs, companies or industries. The available booth formats include regular exhibition stands in sizes of 6 m² and 12 m². Additionally, smaller booths of 1.5 m² and poster booths are also offered. The configuration of each booth type is given below.

The fees for each booth type and exhibitor category are as follows:

	TAV EXCL	TAV INCL
Booth 06 m ² – Project	1350€	1660.50€
Booth 12 m ² – Project	2700€	3321€
Booth 06 m ² – Business	2700€	3321€
Booth 12 m ² – Business	5400€	6642€
Small Booth (1.5 m ² – SME)	1100€	1353€
Poster Booth	400€	492€

Booth assignments will be determined by the organizer.

Regular Booth

The regular exhibition booths of 6 m² and 12 m² include:

- Booth walls constructed with beMatrix frames (height: 250 cm)
- White HDF infill panels
- 1 name mentioned on the wall for 6 m² (X1)/2 names mentioned on the wall for 12 m² (X1, X2)
- 1 external sign with the booth number and logo (L1)
- 3 LED spotlights on arms for 6 m² booth/ 2 LED spotlights on arms for 12 m² booth
- 1 power outlet (500 W)
- 1 table (70x120 cm) & 2 chairs for 6 m²/ 2 tables & 4 chairs for 12 m²

6 m² booth layout:

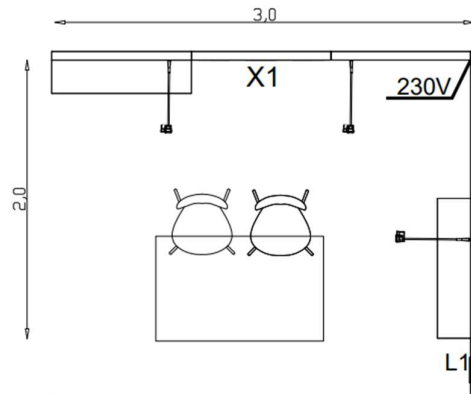

Graphics:
X1 - 900x500 mm
L1 - number of the stand and logo 400x400 mm

12 m² booth layout:

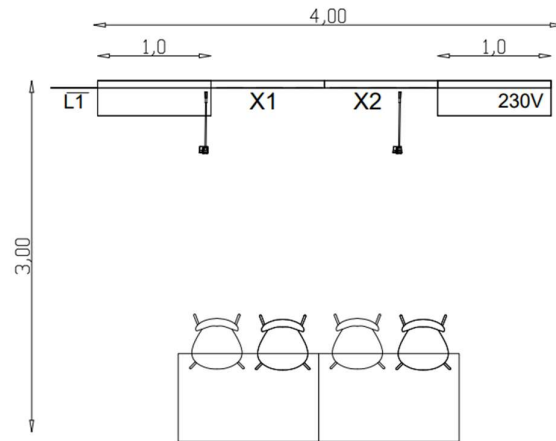
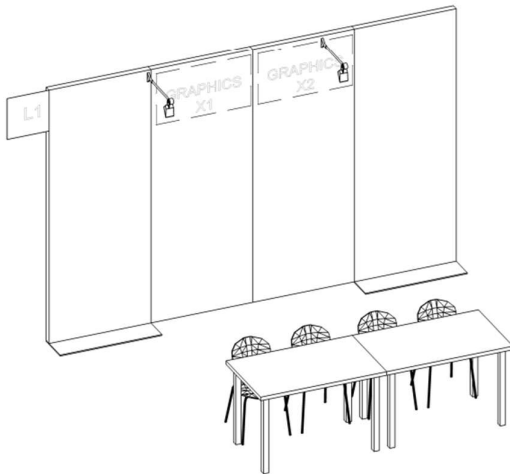

Graphics:
X1, X2 - 900x500 mm
L1 - number of the stand and logo 400x400 mm

Small Booth

The exhibition Small Booth includes:

- The rear wall constructed with beMatrix frames (height: 250cm)
- White HDF infill panels
- 1 name mentioned on the wall
- 1 LED spotlight on arm
- 1 power outlet (500W)
- 1 table & 1 chair

Small booths will be arranged in rows:

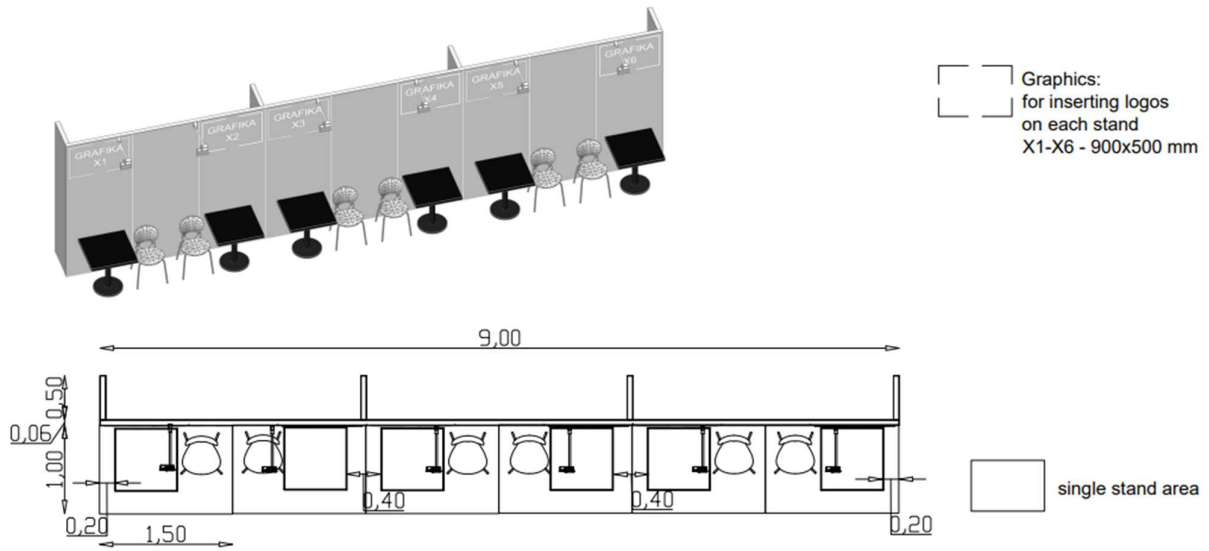

Poster Booth

The exhibition Poster Booth includes:

- The 1 m width and 2 m height white HDF panel on the beMatrix frame
- Space for customized printed graphic (X1)
- Poster area (P)
- 1 business card tray

Poster Booth layout:

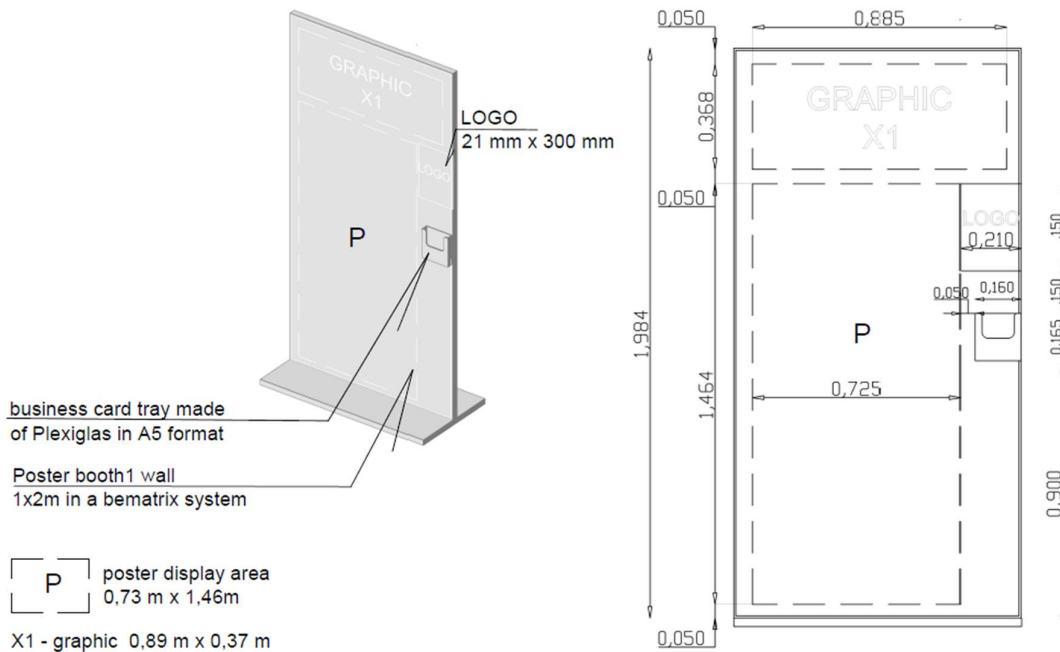

Additional Equipment

Upon receiving confirmation of your booth reservation, you will have the option to order additional equipment (not included in booth price - subject to additional payment). Additional options include:

- Furniture:
 - Furniture package 1 (100€ TAV EXCL): 1 high table (20€ TAV EXCL) + 2 barstools (80€ TAV EXCL)
 - Furniture package 2 (224€ TAV EXCL): 1 lockable counter (154€ TAV EXCL), 1 brochure holder (30€ TAV EXCL) and 1 barstool (40€ TAV EXCL)
 - Furniture package 3 (186€ TAV EXCL): 1 lockable 1x1 m platform (116€ TAV EXCL), 1 brochure holder (30€ TAV EXCL) and 1 barstool (40€ TAV EXCL)
 - All these items are also available separately
- LCD screen 40-65':
 - 40-42' stand-alone TV (119€ TAV EXCL), mounted on the wall (136€ TAV EXCL)
 - 48-50' stand-alone TV (152€ TAV EXCL), mounted on the wall (232€ TAV EXCL)
 - 55' stand-alone TV (176€ TAV EXCL), mounted on the wall (256€ TAV EXCL)
 - 60-65' stand-alone TV (254€ TAV EXCL), mounted on the wall (334€ TAV EXCL)
- Graphics:
 - Printed panel: full color print per panel on the HDF board (2.5 m2) (99.90€ TAV EXCL)
 - Printed PCV panel to brand the counter (1 x 1m) (44€ TAV EXCL)
 - Printed fabric 250 cm height: seamless printing that covers the entire wall (884€ TAV EXCL for 6 m² booth, 1768€ TAV EXCL for 12 m² booth)
 - All prices include adjusting the graphic file for printing
- Electrical Equipment:
 - LED spot on arm (7€ TAV EXCL)
 - Socket 230 V (22€ TAV EXCL)
 - Power connection:
 - 0.1-3.0 kW (1 x 16 A) (108€ TAV EXCL)
 - If a higher-power connection is required, please contact our Technical Team
- Plants:
 - Palm tree in a pot, height 170 cm (114€ TAV EXCL)
 - Small decorative plant in a pot (19.90€ TAV EXCL)

For ordering additional equipment, please reach out directly to Sara Zabor from the Technical Team at PCC to arrange details.

E-mail: sara.zabor@grupamtp.pl

Phone: +48 735 274 699

Electricity

A standard connection to the electricity grid is provided (limited to 500W) and is included in the rental fee. However, we kindly advise bringing or ordering sufficient extension cords and junction boxes with you so that you can connect to the electricity grid easily.

In case a specific power connection is required for your demo please contact Sara Zabor from the Technical Team at PCC to arrange details.

E-mail: sara.zabor@grupamtp.pl

Phone: +48 735 274 699

Access and Registration

Each participant of the exhibition is required to register at the conference, including the complimentary registrations available with a booth rental. Registration of the participants will be possible after receiving the confirmation for the booth rental and will be done via the conference registration system. More details will be provided later.

A conference registration (R-5-E– Exhibitor Conference Registration) is included in the fee paid for the exhibition booth, for 1 or 2 persons, respectively for 6m² or 12m² booths. Similarly, for an SME Demo a single registration (R-5-E– Exhibitor Conference Registration) is included in the fee. All the other participants need to register and pay the registration fee.

DELIVERIES

Pre-Congress Deliveries (Large shipments / Palletized goods)

Pre-Congress deliveries are recommended for larger shipments, especially palletized goods. These deliveries must be coordinated in advance through the official forwarding partners listed below to ensure smooth handling and on-time delivery to the exhibition space.

Recommended forwarding partners:

The following services are provided by the official forwarding companies of the Poznań International Fair:

- unloading and loading of the exhibition articles with no weight limit,
- transport of the exhibition articles to the exhibition space,
- usage of a crane,
- empty boxes storage,
- customs clearance.

Contact Details:

Transmeble International Sp. z o.o.

Ul. M. Konopnickiej 19/2, 60-771 Poznań, POLAND

Phone: +48 61 865 68 07, +48 61 865 75 11

E-mail: office@transmeble.com.pl

Website: www.transmeble.com.pl

Other recommended forwarding companies:

Netlog Polska Sp. z o.o.

Office located at the fairgrounds (MTP area)

Phone: +48 509 145 000

E-mail: poznannetlog@netlog.org.pl

Poznań International Fair – Transport Section

Services include unloading/loading, transport of exhibits (up to 5 tons), and storage of empty packaging.

Address: ul. Głogowska 14, 60-734 Poznań, POLAND

Phone: +48 61 869 23 33

Fax: +48 61 869 23 30

E-mail: tech@mtp.pl

Important:

Please contact your chosen forwarding company **at least 1 month before the event** to arrange logistics services. Official forwarders offer unloading and loading of exhibits (no weight limit), transport to the booth, crane services, storage of empty packaging, and customs clearance assistance.

Direct deliveries (Small packages / Non-palletized goods), since 19.05.2025 (no earlier)

Small shipments, such as packages or small crates, can be sent directly to the venue.

Please note that direct deliveries can be send no earlier than 19.05.2025.

Each package should be addressed in the following way:

Address:

Międzynarodowe Targi Poznańskie sp. z o.o.
ul. Głogowska 14, Brama A, Garden City (Śniadeckich 23A)
60-734 Poznań, POLAND

Stockroom: Pavilion PCC – Magazyn KZ

Contact person: Hubert Joachimiak

E-mail: hubert.joachimiak@mtp.pl,

Mobile: +48 691 023 352

Event: EUCNC & 6G SUMMIT 2025 (Pavilion PCC)

Sender/exhibitor: name of the exhibitor, booth number, contact person, phone number

Packages delivered to this address will be stored at the PCC warehouse until collected.

Note: Only small, non-palletized deliveries are accepted directly. For large shipments, please coordinate through the recommended forwarding partners.

This magazine will operate for EUCNC & 6G Summit during the period 19 May 2025 – 13 June 2025, on weekdays only (Monday to Friday), from 8:00 AM-4:00 PM.

Parcels must be collected by a courier (arranged by the exhibitor) no later than 13 June 2025, which is one week after the end of the conference. Any materials to be returned must be properly packed and clearly marked with return labels by the exhibitor.

Important: Insurance of materials sent by courier is at the exhibitor's expense (MTP does not take financial responsibility for sending, storing and leaving parcels for collection by couriers).

GENERAL RULES & DISCLAIMERS

- All activities organised by companies involving participants in EuCNC 2025 are to be decided on in consultation with both the Organising and the Scientific Committees.
- The organisers reserve the right to change the exhibition floor plans if necessary.
- Liability: in participating in EuCNC 2025 as a sponsor, companies agree that neither EuCNC 2025, the Organising Committee nor the Secretariat assume any liability whatsoever. Companies are requested to make their own arrangements in respect of insurance and organisation of their booth.
- In case of "Force Majeure" neither EuCNC 2025 as the organisers, nor PCO accept any liability.
- The organisers do not, in any manner, endorse any of the company product claims displayed or services provided in the exhibition during EuCNC 2025. The information given and the activities organised by companies are under their own full responsibility.
- By reserving a booth or sponsorship through the Reservation Contract, companies agree that they will not make any legal claims against EuCNC 2025, the Organising Committee, Congress Organisers, PCO, the Local Organisers, etc.
- Distribution of drinks and meals must be in compliance with the rules of the PCO, which has its own caterer
- The general rules of the PCO are applicable to all sponsorship.

TERMS OF PAYMENT

Orders for exhibition space and booths are made through the registration system (<https://eucnc2025.systemcoffee.pl/>). Once the registration process is completed, you will receive a pro forma invoice (with a 14-day payment term) or you can choose to pay online.

If you wish to order any additional items not included in the standard offer, please contact Sara Zabor (sara.zabor@grupamtp.pl, +48 735 274 699). After confirming the order for additional services with Sara Zabor, you will receive an email with an invoice for a non-refundable payment of the total amount of the booking. This invoice must be paid within 14 days. If the payment is not made on time, the exhibition space and any other sponsorship items will become available again.

Please make sure to clearly mention the invoice number with all payments.